

***TM 55-1520-240-PM**

PHASED MAINTENANCE CHECKLIST

CH-47D HELICOPTER

* This manual supersedes TM 55-1520-240-PM, dated 18 October 1990, including all changes.

DISTRIBUTION STATEMENT A: Approved for public release; distribution is unlimited.

**HEADQUARTERS, DEPARTMENT OF THE ARMY
25 MAY 2003**

TM 55-1520-240-PM

WARNING SUMMARY

WARNING

Certain inspections are mandatory safety-of-flight requirements, and the inspection intervals cannot be exceeded. In the event these inspections cannot be accomplished at the specified interval, the helicopter condition status symbol will be immediately changed to a red X.

NOTE

Inspection items contained in this manual are considered the minimum requirements for performing phased maintenance and must be performed. The cumulative effects of inspection deferrals are unknown and could result in catastrophic failure or increased maintenance at a later date.

a/(b blank)

URGENT

TM 55-1520-240-PM
C1

CHANGE

NO. 1

HEADQUARTERS
DEPARTMENT OF THE ARMY
WASHINGTON, D.C., 30 SEPTEMBER 2005

PHASED MAINTENANCE CHECKLIST CH-47D HELICOPTER

DISTRIBUTION STATEMENT A: Approved for public release; distribution is unlimited.

TM 55-1520-240-PM, dated 25 May 2003, is changed as follows:

1. Remove and insert pages as indicated below. New or changed text material is indicated by a vertical bar in the margin. An illustration change is indicated by a miniature pointing hand.

Remove Pages

A/(B blank)
2-51 and 2-52
2-59 and 2-60
2-71 and 2-72
2-89 and 2-90

Insert Pages

A/(B blank)
2-51 and 2-52
2-59 and 2-60
2-71 and 2-72
2-89 and 2-90

2. Retain this sheet in front of manual for reference purposes.

TM 55-1520-240-PM
C1

By Order of the Secretary of the Army:

Official:

SANDRA R. RILEY
*Administrative Assistant to the
Secretary of the Army*
0526308

PETER J. SCHOOMAKER
*General, United States Army
Chief of Staff*

DISTRIBUTION:

To be distributed in accordance with Initial Distribution Number (IDN) 310196 requirements for TM 55-1520-240-PM.

LIST OF EFFECTIVE PAGES

Insert latest changed pages; dispose of superseded pages in accordance with regulations.

NOTE: On a changed page, the portion of the text affected by the latest change is indicated by a vertical line, or other change symbol, in the outer margin of the page. Changes to illustrations are indicated by miniature pointing hands. Changes to wiring diagrams are indicated by shaded areas.

Dates of issue for original and changed pages are:

Original	25 May 2003	Change 1	30 September 2005
Page No.	*Change No.	Page No.	*Change No.
Cover	0	2-61 through 2-71	0
a	0	2-72	1
b blank	0	2-73 through 2-89	0
A	1	2-90	1
B blank.....	1	2-91	0
1-1 through 1-13	0	2-92 blank.....	0
1-14 blank.....	0		
2-1 through 2-50	0		
2-51	1		
2-52 through 2-59	0		
2-60.....	1		

*Zero in this column indicates an original page.

PHASED MAINTENANCE CHECKLIST
CH-47D HELICOPTER

REPORTING ERRORS AND RECOMMENDING IMPROVEMENTS

You can improve this manual. If you find any mistakes or if you know of a way to improve these procedures, please let us know. Mail your letter or DA Form 2028 (Recommended Changes to Publications and Blank Forms) located in the back of this manual, directly to: Commander, U.S. Army Aviation and Missile Command, ATTN: AMSAM-MMC-MA-NP, Redstone Arsenal, AL 35898-5000. A reply will be furnished to you. You may also provide DA Form 2028 information to AMCOM via e-mail, fax, or the World Wide Web. Our fax number is: DSN 788-6546 or Commercial 256-842-6546. Our e-mail address is: 2028@redstone.army.mil. Instructions for sending an electronic 2028 may be found at the back of this manual immediately preceding the hard copy 2028. For the World Wide Web use: <https://amcom2028.redstone.army.mil>.

DISTRIBUTION STATEMENT A: Approved for public release; distribution is unlimited.

TABLE OF CONTENTS

SECTION I. GENERAL INFORMATION

Phased Schedule	1-1
Exceeding the Phased Schedule	1-2
Maintenance Activities	1-3
Limitations	1-4
Pre-Inspection Maintenance Test Flight (MTF)	1-5
Special Inspections, Calendar Inspections, and Lubrication Requirements	1-6
Time Between Overhaul (TBO) and Retirement Life Items Check	1-7
Using the Phased Maintenance Inspection Checklist	1-8
Final Record Check	1-9
Signature Sheet	1-10
Maintenance Operational Checks (MOCs)	1-11
Maintenance Test Flight	1-12
Checklist Disposition	1-13
Inspection Areas	1-14
Serial Number Checklist	1-15

PARA

SECTION II. INSPECTION CHECKLIST

Area 0 – Preparation
Area 1 – Nose
Area 2 – Left Fuselage
Area 3 – Right Fuselage
Area 4 – No. 1 Engine
Area 5 – No. 2 Engine
Area 6 – Aft Rotor and Pylon
Area 7 – Forward Rotor, Crown, and Tunnel
Area 8 – Ramp
Area 9 – Cabin
Area 10 – Cockpit
Power On Checks
Final Inspection

* This manual supersedes TM 55-1520-240-PM, dated 18 October 1990, including all changes.

SECTION I. GENERAL INFORMATION

1-1. PHASED SCHEDULE.

This phased maintenance inspection checklist contains requirements for inspection of the CH-47D helicopter on a phase schedule having **800-hour** (flight hour) cycle with **200-hour** phases. Each requirement included herein is designated for accomplishment at least once, but not more than **four times** during the **800-hour** cycle.

1-2. EXCEEDING THE PHASED SCHEDULE.

a. The phased maintenance inspection intervals designated are the maximum and shall not be exceeded except in actual operational emergencies as explained herein. It is the Commander's responsibility to determine, on an individual helicopter basis, when inspection intervals may be exceeded. For this purpose, operational emergencies are conditions of combat or conditions of disaster which necessitate flight to evacuate aircraft or personnel. Those inspections annotated with a "C" in the Inspect Phase No's column, along with all applicable aircraft forms as addressed in DA PAM 738-751 items that are due, are considered the MINIMUM mandatory combat maintenance inspection requirements for helicopters scheduled for imminent deployment to, or stationed in, a combat environment. Under no circumstances will two combat maintenance inspections be performed sequentially.

b. When the aircraft is operated beyond the normal inspection due time because of such emergency situations, a circled red X status symbol and an appropriate statement, to include authority, must be entered on applicable aircraft forms as addressed in DA PAM 738-751, until such time as the

inspection is complete. When inspections are delayed to meet emergency requirements, Commander will assure that the helicopter status symbol is changed to a red X and that the delayed inspections are accomplished immediately upon termination of the actual emergency.

c. When unusual local conditions of environment, utilization, mission, experience of flight crew and maintenance personnel, periods of inactivity, etc. are encountered, the Maintenance Officer will, at his discretion, increase the scope and/or frequency of maintenance or inspection as necessary to insure safe flight. Refer to TM 1-1500-328-23.

1-3. MAINTENANCE ACTIVITIES.

The inspections prescribed by this checklist will be accomplished at specified phases by Aviation Unit Maintenance (AVUM) activities with assistance of Aviation Intermediate Maintenance (AVIM) and Depot Maintenance activities when required. Space is provided for inspecting personnel to record faults and/or remarks and corrective action taken.

1-4. LIMITATIONS.

The checklist does not contain instructions for repair, adjustment, or other means of rectifying conditions. Neither does it contain special tolerances, limits, or instructions for special troubleshooting to find causes of malfunctions. Such data will be obtained from the TM 55-1520-240-23, Maintenance Manual, and TM 55-1520-240-T, Troubleshooting Manual.

TM 55-1520-240-PM

1-5. PRE-INSPECTION MAINTENANCE TEST FLIGHT (MTF).

A pre-inspection MTF to duplicate non-hazardous equipment problems, to determine unsatisfactory conditions and equipment operation problems, etc., is recommended prior to start of aircraft disassembly for Phased Maintenance inspection; the decision to perform the pre-inspection MTF, however, shall be the responsibility of the unit Maintenance Officer.

1-6. SPECIAL INSPECTIONS, CALENDAR INSPECTIONS, AND LUBRICATION REQUIREMENTS.

Special inspections, calendar inspections, and lubrication requirements contained in TM 55-1520-240-23-1 and those listed on the applicable aircraft forms as addressed in DA PAM 738-751 shall be reviewed and accomplished in accordance with the "inspection due" requirements specified in those documents.

1-7. TIME BETWEEN OVERHAUL (TBO) AND RETIREMENT LIFE ITEMS CHECK.

Prior to start of the applicable phased maintenance inspection, a check will be made of components and their remaining operating hours prior to removal. Refer to the latest issue of TM 55-1520-240-23-1 and all applicable aircraft forms as addressed in DA PAM 738-751 for a complete listing of components and their TBO and retirement life.

1-8. USING THE PHASED MAINTENANCE INSPECTIONS CHECKLIST.

For use of the checklist, refer to DA PAM 738-751 and Figure 1-1.

1-9. FINAL RECORD CHECK.

After all corrective actions have been completed and following completion of the phased inspection, the Technical Inspector shall verify that all applicable forms and records have been properly updated. All uncorrected faults shall be entered on applicable aircraft forms as addressed in DA PAM 738-751. A Final Records Checklist (Figure 1-2) is provided to ensure that forms and records have been inspected for completeness and accuracy prior to release of the aircraft from the phased maintenance inspection. Upon completion, the inspector verifying the final record check, shall enter his initials adjacent to the indicated form or record on the Final Record Checklist.

1-10. SIGNATURE SHEET.

All personnel performing inspection and/or maintenance tasks shall place their signatures and initials on the Signature Sheet (Figure 1-3). The purpose of the signature sheet is to provide a correlation between the initials entered on the individual checklist sheets and the actual names of the personnel accomplishing these tasks.

TM 55-1520-240-PM

1-11. MAINTENANCE OPERATIONAL CHECKS (MOCS).

After the completion of any required corrective action to any of the components of a functional system of the aircraft, MOCs shall be performed on that system to determine the effectiveness of the maintenance actions performed and to verify the proper operation of that system (refer to TM 55-1520-240-T). These MOCs shall be performed in accordance with TM 1-1500-328-23.

1-12. MAINTENANCE TEST FLIGHT (MTF).

When all required inspections in Section II have been accomplished and initialed in accordance with the above procedures, the MTF shall be performed in accordance with the requirements of TM 1-1520-240-MTF and TM 1-1500-328-23 using the MTF form in the TM 1-1520-240-MTF manual.

1-13. CHECKLIST DISPOSITION.

The completion of each phased maintenance inspection shall be recorded on applicable aircraft forms as addressed in DA PAM 738-751. The signed

checklist, together with all forms prescribed by DA PAM 738-751 will be filed for a period of **six months**. At the end of the six-month period, disposition of forms will be in accordance with DA PAM 738-751.

1-14. INSPECTION AREAS.

Figure 1-4 shows the inspection area of the CH-47D aircraft. Figure 1-5 shows the location of access doors and panels which require removal at various phased maintenance inspections.

1-15. SERIAL NUMBER CHECKLIST (FIGURE 1-6) AND EQUIPMENT INVENTORY CHECK.

After all corrective actions have been completed and following completion of the Phased Inspection, the Technical Inspector shall make a serial number verification check, aircraft component historical record and an aircraft equipment inventory check in accordance with DA PAM 738-751.

TM 55-1520-240-PM

PHASE NO. _____		Area Name and No. RIGHT FUSELAGE AREA #3		Aircraft Serial No.	Date
Inspect Phase No's	Inspection Requirements	Status	Faults and/or Remarks	Action Taken	Initial
1, 3	3.1 Service forward and aft landing gear struts. Check ground contact proximity switch and target for proper rigging and gap, IAW TM 55-1520-240-23.		SEE DA 2408-13-2 Pg 3-1A	INSP COMP	RV
ALL	3.2 Heater fuel solenoid valve for leaks, electrical connector, mounting bracket, and attaching hardware for security. Access 21			INSP OK	RV
ALL	3.3 Hydraulic ground power service panel connections for leaks. Dust cap secure. Access 12			INSP OK	RV
ALL	3.4 Fluid drain lines for damage and obstructions.			INSP OK	RV
ALL/C	3.5 Aft landing gear brake (disc and linings).		SEE DA 2408-13-1 PAGE 13	INSP COMP	RV
ALL	3.6 Aft landing gear brake hoses for leaks, chafing, and damage.			INSP OK	RV
ALL	3.7 Swivel lock, swivel housing, and power steering, actuator assembly for leaks.			INSP OK	RV
ALL/C	3.8 Remove, clean, inspect, and repack aft landing gear wheel bearings.		SEE DA 2408-13-2 PAGE 3-1A	INSP COMP	RV

"FOD REMINDER"

Check work area for tools and parts after completion of maintenance and inspection.

Figure 1-1. Example of Using the Phased Maintenance Checklist

TM 55-1520-240-PM

This checklist is provided to insure the indicated forms and records have been inspected for presence, completeness, legibility, and accuracy prior to releasing the aircraft from a phase inspection. Verification of inspection will be indicated by placing the initials of the inspector in the appropriate block.

AIRCRAFT LOG BOOK	INITIALS
DA FORM 2408	
DA FORM 2408-12	
DA FORM 2408-13	
DA FORM 2408-14	
DA FORM 2408-18	
DA FORM 2408-20	
TM 55-1520-240-PMD	
TM 1-1520-240-MTF	
LOCALLY REQUIRED FORMS	

HISTORICAL RECORDS	INITIALS
DA FORM 2408-5	
DA FORM 2408-15	
DA FORM 2408-16	
DA FORM 2408-17	
DA FORM 2408-19	
LOCALLY REQUIRED FORMS	

PRODUCTION CONTROL RECORDS	INITIALS
FLOW CHART	
STATUS BOARD	
WORK ORDER FILE	
MWO FILE	
2405 LOG	
1352 REPORTS	
LOCAL REPORTS	

QUALITY CONTROL	INITIALS
TBO FILE	
QA FILE	
SERIAL NUMBER FILE	
AOAP FILE	
INVENTORY RECORD	
WEIGHT AND BALANCE	
MSG FILE	
DA FORM 2410 SUBMITTED	
LOCAL RECORDS	

Figure 1-2. Final Record Checklist

TM 55-1520-240-PM

Signature of Person Accomplishing Necessary Work	Initial
Signature of Person Accomplishing Necessary Work	Initial
Signature of Person Accomplishing Necessary Work	Initial
Signature of Person Accomplishing Necessary Work	Initial
Signature of Person Accomplishing Necessary Work	Initial
Signature of Person Accomplishing Necessary Work	Initial
	Initial
	Initial
Signature of Maintenance Supervisor	Initial
Signature of Technical Inspector	Initial
Signature of Maintenance Officer	Initial

Figure 1-3. Signature Sheet

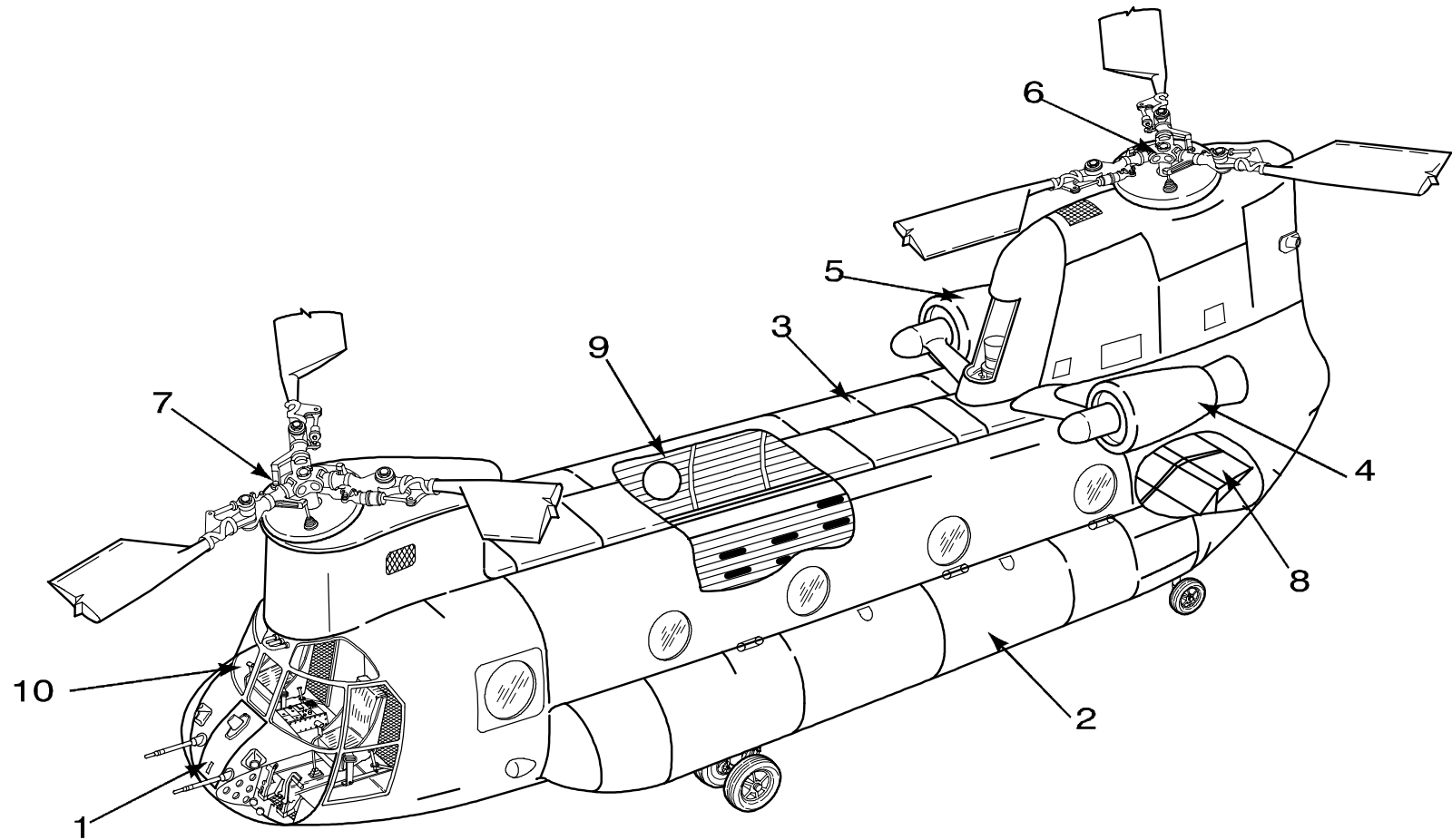

Figure 1-4. Area Diagram (Sheet 1 of 2)

CH-47D Inspection Areas

Area No. 1	Nose	External fuselage from STA 120.00 RH to STA 120.00 LH, excluding Area No. 7, but including those internal areas visible or accessible from outside.
Area No. 2	Left Fuselage	External fuselage from STA 120.00 LH aft to STA 630.50, including bottom of fuselage, but excluding Areas 6 and 7.
Area No. 3	Right Fuselage	External fuselage from STA 630.50 forward to STA 120.00 RH, including bottom of fuselage, but excluding Areas 6 and 7.
Area No. 4	No. 1 Engine	Left hand engine installation including transmission, cowling, fairings, and engine drive shaft.
Area No. 5	No. 2 Engine	Right hand engine installation including transmission, cowling fairings, and engine drive shaft.
Area No. 6	Aft Rotor and Pylon	Internal and external areas of aft pylon from STA 630.50 forward to STA 440.00, excluding Areas 2 and 3.
Area No. 7	Forward Rotor, Crown and Tunnel	Internal and external areas of upper fuselage from STA 440.00 forward to STA 62.00, excluding Areas No. 1, 2, and 3.
Area No. 8	Ramp	Internal fuselage from STA 630.50 forward to STA 482.00.
Area No. 9	Cabin	Internal fuselage from STA 482.00 forward to STA 120.00.
Area No. 10	Cockpit	Internal fuselage from STA 120.00 forward to STA 21.50 excluding Area No. 1.

Figure 1-4. Area Diagram (Sheet 2 of 2)

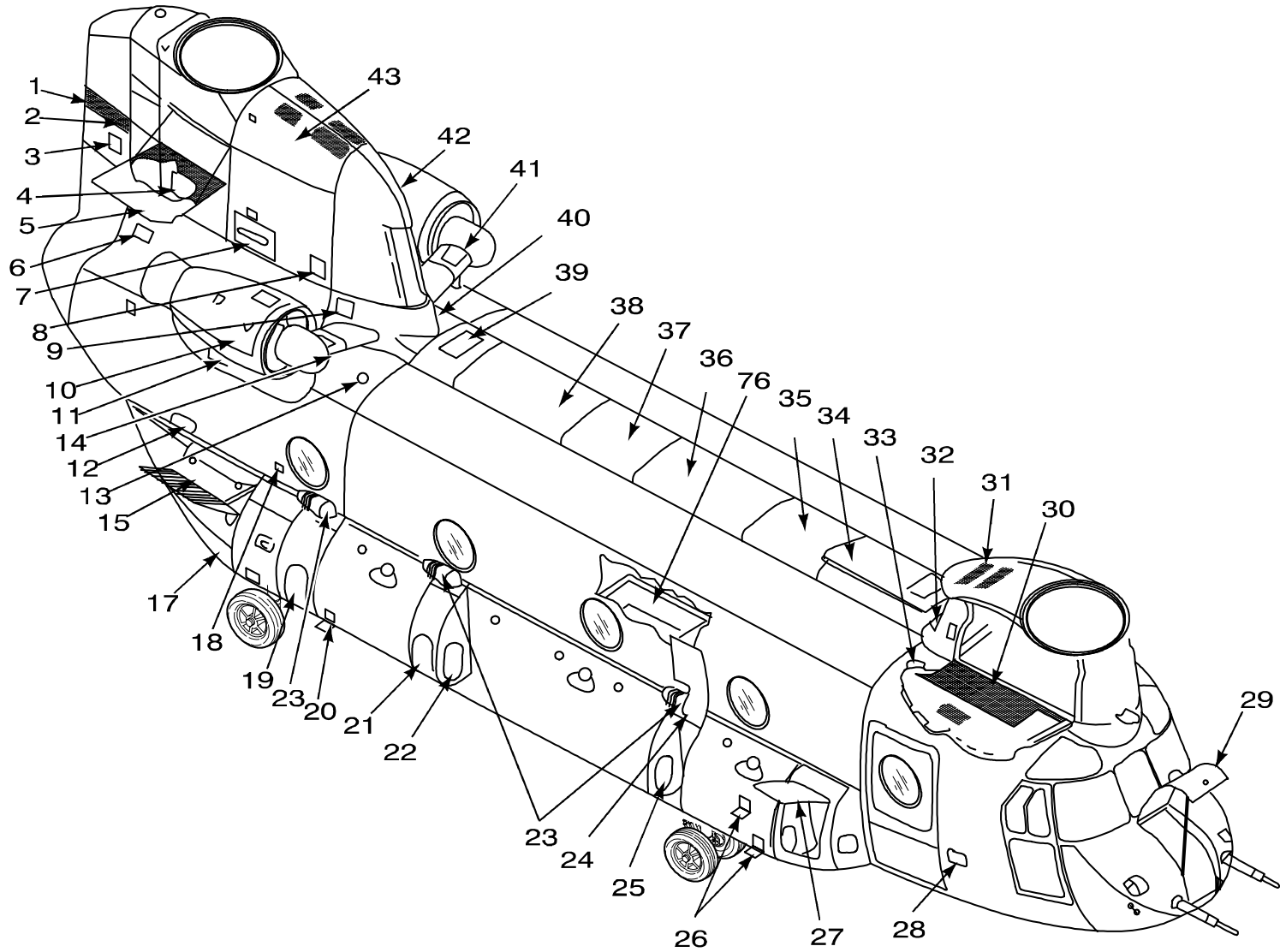

Figure 1-5. Access Doors, Covers, and Panels (Sheet 1 of 3)

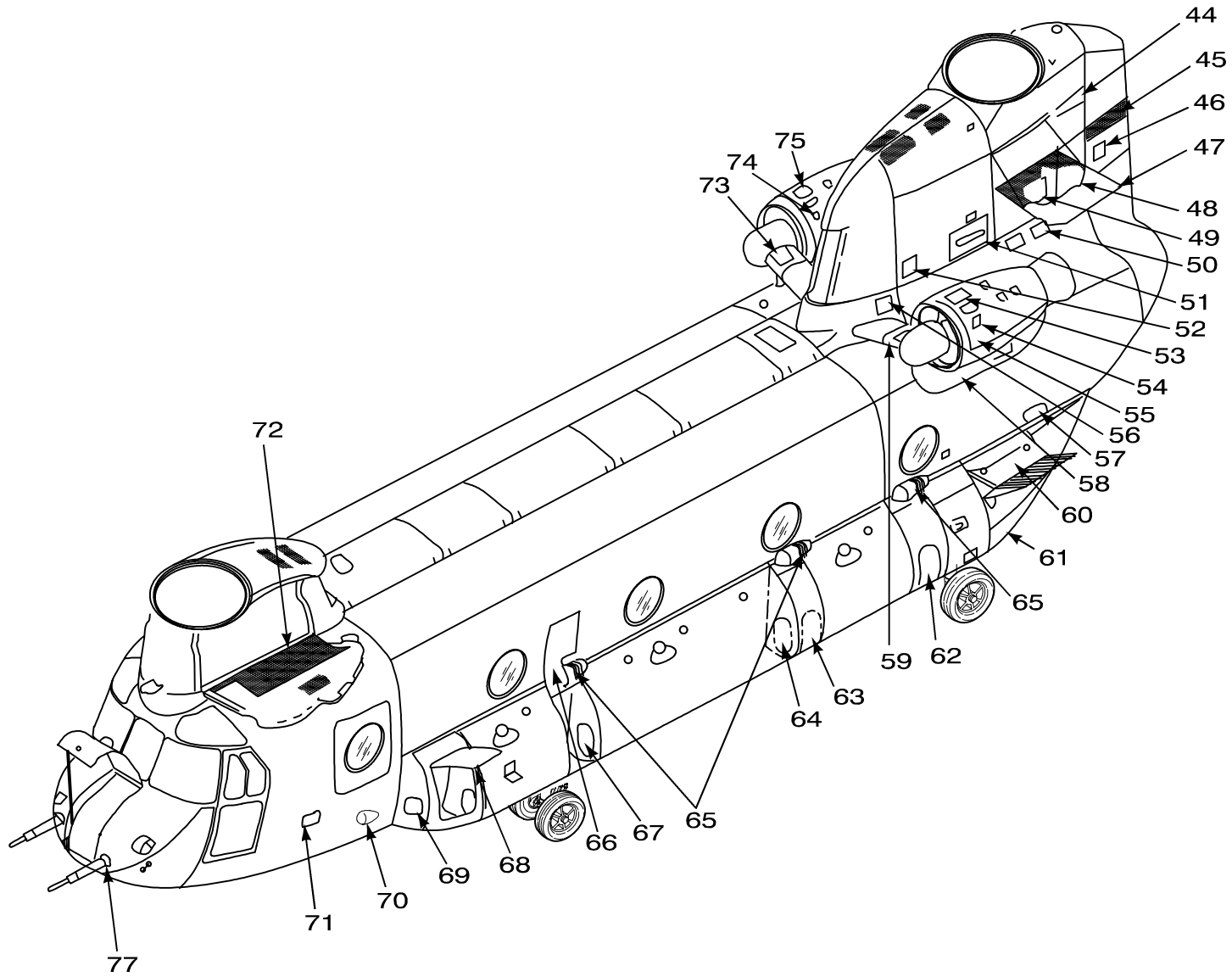

Figure 1-5. Access Doors, Covers, and Panels (Sheet 2 of 3)

TM 55-1520-240-PM

1. Radar warning antenna access door
2. Upper pylon access panel
3. Pylon removal access panel
4. Aft transmission access cover
5. Work platform
6. Generator access door
7. Access cover
8. Hydraulic module inspection access cover
9. Combining transmission access door
10. Engine upper cover
11. Lower engine access door
12. Aft hydraulic service panel
13. Maintenance crane installation access panel
14. Lower hinged access panel
15. Work platform
16. Deleted
17. Aft landing gear access panel
18. Aft interphone jack and ramp control access
19. Aft pod access panel
20. Fuselage foldout step
21. Center pod access panel
22. Main tank aft fuel boost pump access panel
23. Fuel tank vent access panels
24. Forward landing gear access panel
25. Main tank forward fuel boost pump access panel
26. Fuselage foldout steps
27. Electrical compartment access door
28. Interphone jack access door
29. Nose compartment access door
30. Work platform
31. Forward transmission fairing hydraulic module access door
32. Forward transmission fairing hydraulic module access cover
33. Maintenance crane installation access panel
34. Cabin crown access tunnel cover
35. Tunnel access cover
36. Tunnel access cover
37. Tunnel access cover
38. Tunnel access cover
39. Aft crown tunnel access cover
40. Pylon leading edge lower hinged fairing
41. Upper hinged access panel
42. Aft pylon leading edge hinged fairing
43. Aft pylon forward hinged crown fairing
44. Access panel
45. Radar warning antenna access door
46. Pylon removal access panel
47. Work platform
48. Utility hydraulic pump access panel
49. Aft transmission access panel
50. Aft transmission oil filler access door
51. Access cover
52. Hydraulic module inspection access cover
53. Engine oil filler access door
54. Engine oil quantity indicator access door
55. Engine upper cover
56. Combining transmission access door
57. APU emergency fluid shutoff access panel
58. Lower engine access door
59. Lower hinged access panel
60. Work platform
61. Aft landing gear access panel
62. Aft pod access panel
63. Center access panel
64. Main tank aft fuel boost pump access panel
65. Fuel tank vent access panels
66. Forward landing gear access panel
67. Main tank forward fuel boost pump access panel
68. Electrical compartment access door
69. External power receptacles access door
70. Hydraulic ground test access cover
71. Antenna coupler access panel
72. Work platform
73. Upper hinged access panel
74. Engine oil quantity indicator access door
75. Engine oil filler access door
76. Rescue hatch lower door
77. Cockpit ducting access panel

Figure 1-5. Access Doors, Covers, and Panels (Sheet 3 of 3)

TM 55-1520-240-PM

PHASE _____ ACFT S/N _____ ACFT HOURS _____ DATE _____

FWD HEAD _____

FWD BLADES:
 RED _____
 GREEN _____
 YELLOW _____

FWD PITCH CHANGE LINKS:
 RED _____
 GREEN _____
 YELLOW _____

FWD DRIVE ARM _____

FWD SWASHPLATE _____

FWD CYCLIC TRIM ACTUATOR _____

BOLT, FWD CYCLIC TRIM ACTUATOR (UPPER) _____

BEARING, FWD CYCLIC TRIM ACTUATOR (UPPER) _____

BOLT, FWD CYCLIC TRIM ACTUATOR (LOWER) _____

BEARING, FWD CYCLIC TRIM ACTUATOR (LOWER) _____

FWD FIXED LINK _____

BOLT, FWD FIXED LINK (UPPER) _____

BEARING, FWD FIXED LINK (UPPER) _____

BOLT, FWD FIXED LINK (LOWER) _____

BEARING, FWD FIXED LINK (LOWER) _____

FWD SWIVELING ACTUATOR _____

BOLT, FWD SWIVELING ACT. TO SWASHPLATE (UPPER) _____

BOLT, FWD SWIVELING ACT. TO XMSN (LOWER) _____

FWD PIVOTING ACTUATOR _____

BOLT, FWD PIVOTING ACT. TO SWASHPLATE (UPPER) _____

BOLT, FWD PIVOTING ACT. TO XMSN (LOWER) R _____

BOLT, FWD PIVOTING ACT. TO XMSN (LOWER) L _____

FWD TRANSMISSION _____

FWD ADAPTER _____

SYNCH SHAFTS:
 #1 _____
 #2 _____
 #3 _____
 #4 _____
 #5 _____
 #6 _____
 #7 _____
 #8 _____
 #9 _____

COMBINING XMSN ADAPTERS:
 FWD _____
 AFT _____

COMBINING XMSN _____

COMBINING XMSN COOLING FAN _____

COMBINING XMSN COOLING FAN DRIVESHAFT _____

#1 ENGINE _____
 DRIVESHAFT _____
 HUM/FUEL CONTROL _____
 TRANSMISSION _____
 I/B ADAPTER ASSEMBLY _____
 O/B ADAPTER ASSEMBLY _____

#2 ENGINE _____
 DRIVESHAFT _____
 HUM/FUEL CONTROL _____
 TRANSMISSION _____
 I/B ADAPTER ASSEMBLY _____
 O/B ADAPTER ASSEMBLY _____

AFT HEAD _____

AFT BLADES:
 RED _____
 GREEN _____
 YELLOW _____

AFT PITCH CHANGE LINKS:
 RED _____
 GREEN _____
 YELLOW _____

AFT DRIVE ARM _____

AFT SWASHPLATE _____

AFT CYCLIC TRIM ACTUATOR _____

Figure 1-6. Serial Number Checklist (Sheet 1 of 2)

TM 55-1520-240-PM

PHASE _____ ACFT S/N _____ ACFT HOURS _____ DATE _____

BOLT, AFT CYCLIC TRIM ACTUATOR (UPPER) _____

BEARING, AFT CYCLIC TRIM ACTUATOR (UPPER) _____

BOLT, AFT CYCLIC TRIM ACTUATOR (LOWER) _____

BEARING, AFT CYCLIC TRIM ACTUATOR (LOWER) _____

AFT FIXED LINK _____

BOLT, AFT FIXED LINK (UPPER) _____

BEARING, AFT FIXED LINK (UPPER) _____

BOLT, AFT FIXED LINK (LOWER) _____

BEARING, AFT FIXED LINK (LOWER) _____

AFT SWIVELING ACTUATOR _____

BOLT, AFT SWIVELING ACT. TO SWASHPLATE (UPPER) _____

BOLT, AFT SWIVELING ACT. TO AIRFRAME (LOWER) _____

AFT PIVOTING ACTUATOR _____

BOLT, AFT PIVOTING ACT. TO SWASHPLATE (UPPER) _____

BOLT, AFT PIVOTING ACT. TO AIRFRAME (LOWER) R _____

BOLT, AFT PIVOTING ACT. TO AIRFRAME (LOWER) L _____

AFT VERTICAL SHAFT _____

VIBRATION ABSORBERS, SELF TUNING:

NOSE _____

LEFT _____

RIGHT _____

N1 QUADRANT CONTROL _____

DASH ACTUATOR _____

UPPER _____

LOWER _____

DECU (RH) _____

DECU (LH) _____

APU ESU _____

AFT ADAPTER _____

AFT TRANSMISSION _____

APU _____

ASE _____

M-130 CONTROL PANEL _____

M-130 ELECTRONIC MODULE _____

M-130 DISPENSER _____

APR-39 CONTROL PANEL _____

APR-39 INDICATOR _____

APR-39 PROCESSOR _____

APR-39 RECEIVER (F) _____

APR-39 RECEIVER (A) _____

APR-39 ANTENNAS:

FWD RH 1. _____

FWD LH 2. _____

AFT RH 3. _____

AFT LH 4. _____

BOTTOM 5. _____

ALE-47 CONTROL HEAD _____

ALE-47 PROGRAMMER _____

ALE-47 SAFETY SWITCH _____

ALE-47 SEQUENCER (RH) _____

ALE-47 SEQUENCER (LH) _____

ALE-47 DISPENSERS:

1. _____

2. _____

3. _____

4. _____

ALQ 156 CONTROL HEAD _____

ALQ 156 RECEIVER/PROCESSOR _____

ALQ 156 ANTENNA (F) _____

ALQ 156 ANTENNA (A) _____

Figure 1-6. Serial Number Checklist (Sheet 2 of 2)

TM 55-1520-240-PM

SECTION II. INSPECTION CHECKLIST

NOTE

PRIOR TO START OF THE PHASED MAINTENANCE INSPECTION, IT IS RECOMMENDED THAT A PRE-INSPECTION MAINTENANCE TEST FLIGHT (MTF) BE CONDUCTED. ACCOMPLISHMENT OF THE MTF SHALL BE DETERMINED BY THE UNIT MAINTENANCE OFFICER. THE MTF SHOULD BE CONDUCTED BY A MAINTENANCE TEST PILOT FOLLOWING A REVIEW OF THE AIRCRAFT FORMS AND RECORDS AND A BRIEFING FROM THE REGULAR FLIGHT CREW OF THE AIRCRAFT. THE MTF IS RECOMMENDED TO ASSESS THE AIRCRAFT PERFORMANCE AND IDENTIFY DEFICIENCIES THAT SHOULD BE CORRECTED WHILE THE AIRCRAFT IS UNDERGOING PHASED INSPECTION.

TM 55-1520-240-PM

PHASE NO. _____		Area Name and No. PREPARATION		Aircraft Serial No.	Date
Inspect Phase No's	Inspection Requirements	Status	Faults and/or Remarks	Action Taken	Initial
	PREPARATION				
ALL	0.1 Wash engine compressor.				
ALL	0.2 Perform pre-inspection maintenance test flight, if required.				
ALL/C	0.3 Perform all required oil samples.				
ALL	0.4 Clean and prepare aircraft for phase inspection.				
ALL/C	0.5 Aircraft forms and records for recorded faults and current inspection due.				
ALL	0.6 TBO component records for remaining operating hours. Perform Serial Number Check (Figure 1-6).				
ALL	0.7 Perform power on check.				
ALL	0.8 Perform radial and axis play check on all bearings installed on pitch change links, drive arms, dampners and swashplates prior to conducting phase maintenance on helicopter. (Locally produced form shall be used for accountability.)				

"FOD REMINDER"

Check work area for tools and parts after completion of maintenance and inspection.

TM 55-1520-240-PM

PHASE NO. _____		Area Name and No. NOSE AREA #1		Aircraft Serial No.	Date
Inspect Phase No's	Inspection Requirements	Status	Faults and/or Remarks	Action Taken	Initial
	NOSE AREA #1				
1, 2, 3	1.1 Right jettisonable door for security. Release handle for closed and latched position.				
4	1.2 Actuate right jettisonable door latches (upper and lower) and remove door. Door for damage. Seals for cuts, tears, and security. Upper and lower latch plates and mechanism for security, distortion, and wear. Latch mechanism for freedom of motion. Install door. Release handle for closed and locked position.				
ALL	1.3 Nose access door for damage, security, distortion, and wear. Latch mechanism for freedom of motion.				
ALL	1.4 Windshield and cockpit windows for cleanliness, cracks, crazing, and discoloration.				
ALL	1.5 Windshield wipers for condition of blades, security, corrosion, and damage.				

"FOD REMINDER"

Check work area for tools and parts after completion of maintenance and inspection.

TM 55-1520-240-PM

PHASE NO. _____		Area Name and No. NOSE AREA #1		Aircraft Serial No.	Date
Inspect Phase No's	Inspection Requirements	Status	Faults and/or Remarks	Action Taken	Initial
1, 2, 3	1.6 Left jettisonable door for security. Release handle for closed and latched position.				
4	1.7 Actuate left jettisonable door latches (upper and lower) and remove door. Door for damage. Seals for cuts, tears, and security. Upper and lower latch plates and mechanism for security, distortion, and wear. Latch mechanism for freedom of motion. Install door. Release handle for closed and locked position.				
ALL	1.8 Parking brake valve for leaks and security (parking brakes released). Control rod and lever for security. Spring for security, stretched or bent. Reset parking brake.				
ALL	1.9 Brake transfer valves for leaks and security. Access 29				

"FOD REMINDER"

Check work area for tools and parts after completion of maintenance and inspection.

TM 55-1520-240-PM

PHASE NO. _____		Area Name and No. NOSE AREA #1		Aircraft Serial No.	Date
Inspect Phase No's	Inspection Requirements	Status	Faults and/or Remarks	Action Taken	Initial
ALL	1.10 Electrical wiring and connectors for security, visible through right and left chin bubble windshield panels or nose access door. Wires for evidence of chafing, proper support, and condition of insulation. Terminal boards for condition and proper installation of covers. Visible pitot-static and AFCS sideslip port tubing for proper connection and support and not kinked. Access 29				
ALL/C	1.11 Dynamic absorber for security. Support structure for cracks and loose or missing hardware. Access 29				
ALL/C	1.12 Entire area for structural damage, skin cracks, loose or missing rivets, dents and evidence of corrosion. Paint for chipping or peeling. Stencil and decals for condition.				
ALL/C	1.13 Inspect and lubricate the pedal box bearings only if they are removed from the aircraft for other maintenance.				
2, 4	1.14 Inspect ducting for security of clamps, cuts, chaffing, and FOD. Access door and seal for cuts, damage, security, distortion, and wear. Access 77				

"FOD REMINDER"

Check work area for tools and parts after completion of maintenance and inspection.

TM 55-1520-240-PM

PHASE NO. _____		Area Name and No. LEFT FUSELAGE, AREA #2		Aircraft Serial No.	Date
Inspect Phase No's	Inspection Requirements	Status	Faults and/or Remarks	Action Taken	Initial
	LEFT FUSELAGE, AREA #2				
ALL	2.1 Battery charger and connectors for security. Charger for tripped bite indicator. Access 68				
ALL	2.2 Battery and connectors for damage, security, corrosion, cleanliness, and evidence of leakage. Do not open battery top cover.				
ALL	2.3 Battery sump jar and tubing for leaks, security, and adequate acid solution.				
ALL	2.4 Electrical power equipment in left pod for security of mounting. Connectors for proper installation and security.				
ALL/C	2.5 Forward landing gear torque arms for security. Lubricate torque arms.				
ALL/C	2.6 Forward landing gear brake (disks and linings).				
ALL/C	2.7 Forward landing gear support structure for buckling, cracks, corrosion, loose or missing hardware.				

"FOD REMINDER"

Check work area for tools and parts after completion of maintenance and inspection.

TM 55-1520-240-PM

PHASE NO. _____		Area Name and No. LEFT FUSELAGE, AREA #2		Aircraft Serial No.	Date
Inspect Phase No's	Inspection Requirements	Status	Faults and/or Remarks	Action Taken	Initial
ALL	2.8 Forward landing gear strut for leakage, cleanliness of exposed piston, and normal extension (visual).				
ALL	2.9 Forward landing gear brake hoses for leakage, chafing, and damage.				
ALL/C	2.10 Remove, clean, inspect, and repack forward landing gear wheel bearings.				
ALL	2.11 Forward landing gear wheels for cracks, corrosion, and condition of paint. Bolts for torque and sealant.				
ALL	2.12 Fuel pod vents on underside of pods (6 places) for obstructions. Pod cavities for cleanliness and evidence of corrosion. Vent screens (clips) for proper installation and security.				
ALL	2.13 Pitot-static and AFCS sideslip system drain lines. Drain caps installed and secure. Refer to TM 1-1500-204-23.				

"FOD REMINDER"

Check work area for tools and parts after completion of maintenance and inspection.

TM 55-1520-240-PM

PHASE NO. _____		Area Name and No. LEFT FUSELAGE, AREA #2		Aircraft Serial No.	Date
Inspect Phase No's	Inspection Requirements	Status	Faults and/or Remarks	Action Taken	Initial
ALL	2.14 Antennas and supports for damage and security. Doppler antenna for cleanliness.				
ALL	2.15 Hydraulic ground power service panel connections for leakage, dust caps secure.				
ALL	2.16 Fuel pods for dents, skin cracks or holes, bond voids, delaminations, and evidence of trapped fluids under skin.				
ALL	2.17 Inspect fuel pods for corrosion and electrical bonding.				
ALL/C	2.18 Main and auxiliary fuel tanks for evidence of leaks. Filler caps for security. Visible portions of tank vents for damage and obstruction. Vent fairings for security. Sump drains for leaks.				
ALL	2.19 APU fuel pump electrical connector, mounting bracket, and attaching hardware for security. Access 63				

"FOD REMINDER"

Check work area for tools and parts after completion of maintenance and inspection.

TM 55-1520-240-PM

PHASE NO. _____		Area Name and No. LEFT FUSELAGE, AREA #2		Aircraft Serial No.	Date
Inspect Phase No's	Inspection Requirements	Status	Faults and/or Remarks	Action Taken	Initial
1, 3	2.20 Service forward and aft landing gear struts. Check ground contact proximity switch and target for proper rigging and gap IAW TM 55-1520-240-23.				
ALL/C	2.21 Aft landing gear brake (disk and linings).				
ALL	2.22 Aft landing gear brake and hose for leaks, chafing, and damage.				
ALL	2.23 Aft landing gear wheel for cracks and corrosion. Paint for chipping or peeling. Bolts for torque and sealant.				
ALL/C	2.24 Remove, clean, inspect, and repack aft landing gear wheel bearings.				
ALL	2.25 Axle housing retaining bolts (2) for security and corrosion. Interior areas of spindle for corrosion and lack of paint.				
ALL	2.26 Swivel lock and swivel housing for leaks and security.				

"FOD REMINDER"

Check work area for tools and parts after completion of maintenance and inspection.

TM 55-1520-240-PM

PHASE NO. _____		Area Name and No. LEFT FUSELAGE, AREA #2		Aircraft Serial No.	Date
Inspect Phase No's	Inspection Requirements	Status	Faults and/or Remarks	Action Taken	Initial
ALL	2.27 Aft landing gear strut for leaks, cleanliness of exposed piston, normal extension (visual).				
ALL	2.28 Aft landing gear support structure for buckling, cracks, corrosion, and loose or missing fasteners.				
ALL/C	2.29 Aft landing gear drag links for security, corrosion, cracks, nicks, dents, twisting, and displacement of bearings from bores. All surfaces of lower drag link for cracks, with particular attention to area around forward trunnion anti-rotation bolt hole. Access 61				
ALL/C	2.30 Lubricate aft landing gear grease fittings.				
ALL	2.31 Engine water wash system quick disconnect for security and damage. (With 74)				
ALL	2.32 Static ground wire for security and ground contact.				

"FOD REMINDER"

Check work area for tools and parts after completion of maintenance and inspection.

TM 55-1520-240-PM

PHASE NO. _____		Area Name and No. LEFT FUSELAGE, AREA #2		Aircraft Serial No.	Date
Inspect Phase No's	Inspection Requirements	Status	Faults and/or Remarks	Action Taken	Initial
ALL	2.33 Fluid drain lines for damage and obstructions.				
ALL/C	2.34 Access doors, work platforms, and panels for damage. Latching mechanism for security and proper operation. Seals for cuts, tears, cracks, and security. Engine work platform support struts for security, twisting, and proper operation of pins. Access 57, 60, 61, 62, 63, 66, 68, 69, 70				
ALL/C	2.35 Entire area for structural damage, skin cracks, dents or buckling, loose or missing rivets, evidence of corrosion. Paint for chipping or peeling. Stencils and decals for condition.				
ALL	2.36 Static port for obstruction and damage.				

"FOD REMINDER"

Check work area for tools and parts after completion of maintenance and inspection.

TM 55-1520-240-PM

PHASE NO. _____		Area Name and No. RIGHT FUSELAGE AREA #3		Aircraft Serial No.	Date
Inspect Phase No's	Inspection Requirements	Status	Faults and/or Remarks	Action Taken	Initial
	RIGHT FUSELAGE AREA #3				
1, 3	3.1 Service forward and aft landing gear struts. Check ground contact proximity switch and target for proper rigging and gap, IAW TM 55-1520-240-23.				
ALL	3.2 Heater fuel solenoid valve for leaks, electrical connector, mounting bracket, and attaching hardware for security. Access 21				
ALL	3.3 Hydraulic ground power service panel connections for leaks. Dust cap secure. Access 12				
ALL	3.4 Fluid drain lines for damage and obstructions.				
ALL/C	3.5 Aft landing gear brake (disc and linings).				
ALL	3.6 Aft landing gear brake hoses for leaks, chafing, and damage.				
ALL	3.7 Swivel lock, swivel housing, and power steering, actuator assembly for leaks.				

"FOD REMINDER"

Check work area for tools and parts after completion of maintenance and inspection.

TM 55-1520-240-PM

PHASE NO. _____		Area Name and No. RIGHT FUSELAGE AREA #3		Aircraft Serial No.	Date
Inspect Phase No's	Inspection Requirements	Status	Faults and/or Remarks	Action Taken	Initial
ALL/C	3.8 Remove, clean, inspect, and repack aft landing gear wheel bearings.				
ALL	3.9 Aft landing gear wheel for cracks and corrosion. Paint for chipping or peeling. Bolts for torque and sealant.				
ALL	3.10 Axle housing retaining bolts (2) for security and corrosion. Interior area of spindle for corrosion and for paint chipping and peeling.				
ALL	3.11 Aft landing gear strut for leaks, cleanliness of exposed piston, normal extension (visual).				
ALL	3.12 Aft landing gear support structure for buckling, cracks, corrosion, loose or missing fasteners.				
ALL/C	3.13 Aft landing gear drag links for security, corrosion, cracks, nicks, dents, twisting, and displacement of bearings from bores. All surfaces of lower drag link for cracks, with particular attention to area around forward trunnion anti-rotation bolt hole. Access 17				

"FOD REMINDER"

Check work area for tools and parts after completion of maintenance and inspection.

TM 55-1520-240-PM

PHASE NO. _____		Area Name and No. RIGHT FUSELAGE AREA #3		Aircraft Serial No.	Date
Inspect Phase No's	Inspection Requirements	Status	Faults and/or Remarks	Action Taken	Initial
ALL	3.18 Fuel pod vents on underside of pods (6 places) for obstructions. Pod cavities for cleanliness and evidence of corrosion. Vent screens (clips) for proper installation and security.				
ALL	3.19 Inspect fuel pods for corrosion and electrical bonding.				
ALL	3.20 Fuel pods for dents, skin cracks or holes, bond voids, delamination, and evidence of trapped fluids under skin.				
ALL	3.21 Static port for obstruction and damage.				
ALL/C	3.22 Forward landing gear torque arms for security. Lubricate torque arms.				
ALL/C	3.23 Forward landing gear brake (discs and linings).				
ALL	3.24 Forward landing gear brake hoses for leaks, chafing, and damage.				
ALL	3.25 Right forward landing gear wheels for cracks, corrosion and condition of paint. Bolts for torque and sealant.				

"FOD REMINDER"

Check work area for tools and parts after completion of maintenance and inspection.

TM 55-1520-240-PM

PHASE NO. _____		Area Name and No. RIGHT FUSELAGE AREA #3		Aircraft Serial No.	Date
Inspect Phase No's	Inspection Requirements	Status	Faults and/or Remarks	Action Taken	Initial
ALL/C	3.30 Forward external cargo hook retaining bolt (access panel removed) and safety bolt for proper installation and corrosion.				
ALL/C	3.31 Refueling station and panel for security of lights, switches, and refueling nozzle cap. Check for evidence fuel leaks.				
ALL	3.32 Antennas and supports for damage and security.				
ALL	3.33 Electrical power equipment in right pod for security of mounting. Connectors for proper installation and security. Access 27				
ALL	3.34 Heater air intake and exhaust for obstructions. Exhaust for evidence of overheating.				
ALL/C	3.35 Access doors, work platforms, and panels for damage. Latching mechanism for security and proper operation. Seals for cuts, tears, cracks, and security. Engine work platform support struts for security, twisting, and proper operation of pins. Access 12, 15, 17, 18, 19, 21, 24, 27, 28				

"FOD REMINDER"

Check work area for tools and parts after completion of maintenance and inspection.

TM 55-1520-240-PM

PHASE NO. _____		Area Name and No. RIGHT FUSELAGE AREA #3		Aircraft Serial No.	Date
Inspect Phase No's	Inspection Requirements	Status	Faults and/or Remarks	Action Taken	Initial
ALL/C	3.36 Entire area for structural damage, skin cracks, dents or buckling, loose or missing rivets, evidence of corrosion. Paint for chipping or peeling. Stencils and decals for condition.				
ALL/C	3.37 Main and auxiliary fuel tanks for evidence of leaks. Filler caps for security. Visible portions of tank vents for damage and obstruction. Vent fairings for security. Sump drains for leaks.				

"FOD REMINDER"

Check work area for tools and parts after completion of maintenance and inspection.

TM 55-1520-240-PM

PHASE NO. _____		Area Name and No. NO. 1 ENGINE AREA #4		Aircraft Serial No.	Date
Inspect Phase No's	Inspection Requirements	Status	Faults and/or Remarks	Action Taken	Initial
ALL/C	NO. 1 ENGINE AREA #4 4.1 Engine inlet (screen removed) and bypass panels for cleanliness and broken or damaged wire mesh. Fiberglass for cracks or delamination. Fasteners for security and loose or missing hardware. Lower screen inspection panel for security at hinge and latch mechanism. Access 60				
ALL/C	4.2 Engine transmission for leaks, evidence of chafing, cracks, and security of components and hardware. Access 41, 59, 60  Do not remove all bolts from the adapters at the same time during inspection. Adapters are balanced assemblies and requires replacement if all bolts are removed.				

"FOD REMINDER"

Check work area for tools and parts after completion of maintenance and inspection.

TM 55-1520-240-PM

PHASE NO. _____		Area Name and No. NO. 1 ENGINE AREA #4		Aircraft Serial No.	Date
Inspect Phase No's	Inspection Requirements	Status	Faults and/or Remarks	Action Taken	Initial
ALL/C	4.3 Remove engine drive shaft and adapters. Clean, inspect, lubricate, and reinstall. All engine drive shaft lugs and adapter lugs, require 4X power magnifying glass inspection for cracks. If crack is suspected, nondestructive inspection (NDI) verification is required. Access 41, 59, 60				
ALL	4.4 Engine and engine transmission lubrication hoses and fittings for leaks, chafing, damage, and proper support. Wire bundles and connectors for security, damage, chafing, and proper support. Access 41, 59, 60				
ALL/C	4.5 Engine inlet housing and ducts for cleanliness, foreign object damage, and debris. Visible areas of compressor blades and stators for damage and foreign materials. Inlet housing struts and mount pads for cracks. On helicopters (Without 74), refer to TM 55-2840-254-23. On helicopters (With 74), refer to TM 1-2840-265-23.				

"FOD REMINDER"

Check work area for tools and parts after completion of maintenance and inspection.

TM 55-1520-240-PM

PHASE NO. _____		Area Name and No. NO. 1 ENGINE AREA #4		Aircraft Serial No.	Date
Inspect Phase No's	Inspection Requirements	Status	Faults and/or Remarks	Action Taken	Initial
ALL/C	4.6 Engine water wash nozzles for damage, loss of sealant and signs of blockage. (With 74)				
ALL/C	4.7 Engine water wash system hoses and tubes for security, damage, chafing and proper support. (With 74)				
ALL/C	4.8 Engine water wash manifold for cracks, damage, and security of components and attaching hardware. (With 74)				
ALL	4.9 Main electrical, ignition, and thermocouple harnesses for security, damage and chafing. Access 55, 58, 60				
ALL/C	4.10 Main fuel filter and in-line fuel filter bypass indicator for extension.				
ALL	4.11 Accessory drive gearbox for security, leaks, and damage. Access 55, 58, 60				

"FOD REMINDER"

Check work area for tools and parts after completion of maintenance and inspection.

TM 55-1520-240-PM

PHASE NO. _____		Area Name and No. NO. 1 ENGINE AREA #4		Aircraft Serial No.	Date
Inspect Phase No's	Inspection Requirements	Status	Faults and/or Remarks	Action Taken	Initial
ALL/C	4.12 No. 1 engine accessory gearbox chip detector for contamination. Remove inspect, and clean. On helicopters (Without 74), refer to TM 55-2840-254-23. On helicopters (With 74), refer to TM 1-2840-265-23. Access 55, 58, 60				
ALL	4.13 Compressor housing and visible portions of air diffuser for damage and security. Access 55, 58, 60				
ALL	4.14 Compressor bleed band and retainer spacers for wear. Actuator for damage and security. Access 55, 58, 60				
ALL	4.15 Combustion chamber housing and fire shields for cracks, hot spots, burned areas, and buckling. Access 55, 58, 60				
ALL	4.16 Thermocouple bus bars for damage and security. Access 55, 58, 60				
ALL	4.17 Fire detection system sensing elements throughout the area for chafing, damage, and security.				

"FOD REMINDER"

Check work area for tools and parts after completion of maintenance and inspection.

TM 55-1520-240-PM

PHASE NO. _____		Area Name and No. NO. 1 ENGINE AREA #4		Aircraft Serial No.	Date
Inspect Phase No's	Inspection Requirements	Status	Faults and/or Remarks	Action Taken	Initial
ALL	4.18 Main fuel manifolds for security and signs of leaks. Access 55, 58, 60				
ALL	4.19 Lines and hoses throughout the area for leaks, chafing, and security, including quick disconnect shelf.				
ALL/C	4.20 Main oil filter bypass indicator for extension.				
ALL/C	4.21 Remove interstage air bleed strainer. Inspect, clean, and reinstall. On helicopters (Without 74), refer to TM 55-2840-254-23. On helicopters (With 74), refer to TM 1-2840-265-23. Access 55, 58, 60				
ALL/C	4.22 Remove fuel control strainer, if the main fuel filter bypass indicator has been actuated (in bypass). Inspect, clean, and reinstall, not necessary otherwise. On helicopters (Without 74), refer to TM 55-2840-254-23. Access 55, 58, 60				
2, 4	4.23 Replace oil and fuel filters every 400 hours .				

"FOD REMINDER"

Check work area for tools and parts after completion of maintenance and inspection.

TM 55-1520-240-PM

PHASE NO. _____		Area Name and No. NO. 1 ENGINE AREA #4		Aircraft Serial No.	Date
Inspect Phase No's	Inspection Requirements	Status	Faults and/or Remarks	Action Taken	Initial
ALL	4.28 EAPS drive shaft cowling seal for security and condition.				
ALL	4.29 Scavenge duct for obstructions, damage, and condition.				
ALL	4.30 Scavenge fan impellers for visible damage, cracks, and obstructions.				
ALL	4.31 Electrical cables for security, evidence of chaffing, and condition. Electrical connectors for proper installation.				
ALL	4.32 EAPS attachment brackets for cracks, damage, security, and condition.				
ALL	4.33 Attachment rails for security, cracks, damage, and cleanliness.				
ALL	4.34 EAPS air inlet tubes for obstructions, security, and condition.				
ALL	4.35 Bypass door closed and door seal for damage, security, and proper sealing.				
ALL	4.36 EAPS module engine fairing seal for damage, security, and cleanliness.				

"FOD REMINDER"

Check work area for tools and parts after completion of maintenance and inspection.

TM 55-1520-240-PM

PHASE NO. _____		Area Name and No. NO. 1 ENGINE AREA #4		Aircraft Serial No.	Date
Inspect Phase No's	Inspection Requirements	Status	Faults and/or Remarks	Action Taken	Initial
ALL	4.37 Slide EAPS module aft into flight position. Check that the engine fairing seal is properly seated the entire circumference of the fairing and there are no gaps.				
ALL	4.38 Install lockpins, check pin lanyards for security. Check electrical connections.				

"FOD REMINDER"

Check work area for tools and parts after completion of maintenance and inspection.

TM 55-1520-240-PM

PHASE NO. _____		Area Name and No. NO. 2 ENGINE AREA #5		Aircraft Serial No.	Date
Inspect Phase No's	Inspection Requirements	Status	Faults and/or Remarks	Action Taken	Initial
ALL/C	NO. 2 ENGINE AREA #5 5.1 Engine inlet (screen removed) and bypass panels for cleanliness, broken or damaged wire mesh and proper installation. Fiberglass for cracks or delamination. Fasteners for security and loose or missing hardware. Lower screen inspection panel for security at hinge and latch mechanism. Access 15				
ALL/C	5.2 Engine transmission for leaks, evidence of chafing, cracks, and security of components and hardware. Access 14, 15, 73  Do not remove all bolts from the adapters at the same time during inspection. Adapters are balanced assemblies and requires replacement if all bolts are removed.				

"FOD REMINDER"

Check work area for tools and parts after completion of maintenance and inspection.

TM 55-1520-240-PM

PHASE NO. _____		Area Name and No. NO. 2 ENGINE AREA #5		Aircraft Serial No.	Date
Inspect Phase No's	Inspection Requirements	Status	Faults and/or Remarks	Action Taken	Initial
ALL/C	5.3 Remove engine drive shaft and adapters. Clean, inspect, lubricate, and reinstall. All engine drive shaft lugs and adapter lugs, require 4X power magnifying glass inspection for cracks. If crack is suspected, nondestructive inspection (NDI) verification is required. Access 14, 15, 73				
ALL	5.4 Engine and engine transmission lubrication hoses and fittings for leaks, chafing, damage, and proper support. Wire bundles and connectors for security, damage, chafing, and proper support. Access 14, 15, 73				
ALL/C	5.5 Engine inlet housing and ducts for cleanliness, foreign object damage, and debris. Visible areas of compressor blades and stators for damage and foreign materials. Inlet housing struts and mount pads for cracks. On helicopters (Without 74), refer to TM 55-2840-254-23. On helicopters (With 74), refer to TM 1-2840-265-23. Access 15				

"FOD REMINDER"

Check work area for tools and parts after completion of maintenance and inspection.

TM 55-1520-240-PM

PHASE NO. _____		Area Name and No. NO. 2 ENGINE AREA #5		Aircraft Serial No.	Date
Inspect Phase No's	Inspection Requirements	Status	Faults and/or Remarks	Action Taken	Initial
ALL/C	5.6 Engine water wash nozzles for damage, loss of sealant and signs of blockage. (With 74)				
ALL/C	5.7 Engine water wash system hoses and tubes for security, damage, chafing and proper support. (With 74)				
ALL/C	5.8 Engine water wash manifold for cracks, damage, and security of components and attaching hardware. (With 74)				
ALL	5.9 Main electrical, ignition, and thermocouple harnesses for security, damage and chafing. Access 10, 11, 15				
ALL/C	5.10 Main fuel filter and in-line fuel filter bypass indicator for extension.				
ALL	5.11 Accessory drive gearbox for security, leaks, and damage. Access 10, 11, 15				

"FOD REMINDER"

Check work area for tools and parts after completion of maintenance and inspection.

TM 55-1520-240-PM

PHASE NO. _____		Area Name and No. NO. 2 ENGINE AREA #5		Aircraft Serial No.	Date
Inspect Phase No's	Inspection Requirements	Status	Faults and/or Remarks	Action Taken	Initial
ALL	5.12 No. 2 engine accessory gearbox chip detector for contamination. Remove inspect, and clean. On helicopters (Without 74), refer to TM 55-2840-254-23. On helicopters (With 74), refer to TM 1-2840-265-23. Access 10, 11, 15				
ALL	5.13 Compressor housing and visible portions of air diffuser for damage and security. Access 10, 11, 15				
ALL	5.14 Compressor bleed band and retainer spacers for wear. Actuator for damage and security. Access 10, 11, 15				
ALL	5.15 Combustion chamber housing and fire shields for cracks, hot spots, burned areas, and buckling. Access 10, 11, 15				
ALL	5.16 Thermocouple bus bars for damage and security. Access 10, 11, 15				
ALL	5.17 Fire detection system sensing elements throughout the area for chafing, damage, and security.				

"FOD REMINDER"

Check work area for tools and parts after completion of maintenance and inspection.

TM 55-1520-240-PM

PHASE NO. _____		Area Name and No. NO. 2 ENGINE AREA #5		Aircraft Serial No.	Date
Inspect Phase No's	Inspection Requirements	Status	Faults and/or Remarks	Action Taken	Initial
ALL	5.18 Main fuel manifolds for security and signs of leaks. Access 10, 11, 15				
ALL	5.19 Lines and hoses throughout the area for leaks, chafing, and security, including quick disconnect shelf.				
ALL/C	5.20 Main oil filter bypass indicator for extension.				
ALL/C	5.21 Remove interstage air bleed strainer. Inspect, clean, and reinstall. On helicopters (Without 74), refer to TM 55-2840-254-23. On helicopters (With 74), refer to TM 1-2840-265-23. Access 10, 11, 15				
ALL/C	5.22 Remove fuel control strainer, if the main fuel filter bypass indicator has been actuated (in bypass). Inspect, clean, and reinstall. Not necessary otherwise. On helicopters (Without 74), refer to TM 55-2840-254-23. On helicopters (With 74), refer to TM 1-2840-265-23. Access 10, 11, 15				
2, 4	5.23 Replace oil and fuel filters every 400 hours .				

"FOD REMINDER"

Check work area for tools and parts after completion of maintenance and inspection.

TM 55-1520-240-PM

PHASE NO. _____		Area Name and No.		Aircraft Serial No.	Date
		NO. 2 ENGINE AREA #5			
Inspect Phase No's	Inspection Requirements	Status	Faults and/or Remarks	Action Taken	Initial
ALL	5.28 EAPS drive shaft cowling seal for security and condition.				
ALL	5.29 Scavenge duct for obstructions damage and condition.				
ALL	5.30 Scavenge fan impellers for visible damage, cracks, and obstructions.				
ALL	5.31 Electrical cables for security, evidence of chafing, and condition. Electrical connectors for proper installation.				
ALL	5.32 EAPS attachment brackets for cracks, damage, security, and condition.				
ALL	5.33 Attachment rails for security, cracks, damage, and cleanliness.				
ALL	5.34 EAPS air inlet tubes for obstructions, security and condition.				
ALL	5.35 Bypass door closed and door seal for damage, security, and proper sealing.				
ALL	5.36 EAPS module engine fairing seal for damage, security, and cleanliness.				

"FOD REMINDER"

Check work area for tools and parts after completion of maintenance and inspection.

TM 55-1520-240-PM

PHASE NO. _____		Area Name and No. NO. 2 ENGINE AREA #5		Aircraft Serial No.	Date
Inspect Phase No's	Inspection Requirements	Status	Faults and/or Remarks	Action Taken	Initial
ALL	5.37 Slide EAPS module aft into flight position. Check that the engine fairing seal is properly seated the entire circumference of the fairing and there are no gaps.				
ALL	5.38 Install lockpins, check pin lanyards for security. Check electrical connections.				

"FOD REMINDER"

Check work area for tools and parts after completion of maintenance and inspection.

TM 55-1520-240-PM

PHASE NO. _____		Area Name and No. AFT ROTOR AND PYLON, AREA #6		Aircraft Serial No.	Date
Inspect Phase No's	Inspection Requirements	Status	Faults and/or Remarks	Action Taken	Initial
	AFT ROTOR AND PYLON, AREA #6				
2, 4, C	6.1 Drain and service all rotary-wing head reservoirs.				
ALL/C	6.2 Check aft rotary-wing head retaining nut for specified torque. Refer to TM 55-1520-240-23.				
ALL/C	6.3 Inspect the installed horizontal hinge pins and bearings per TM 55-1520-240-23.				
ALL/C	6.4 Perform eddy current inspection of area surrounding the vertical web lightening holes on rotor hubs that contain such lightening holes.				
ALL/C	6.5 Aft rotary-wing head for corrosion, damage, and cracks in pitch varying housing, pitch shaft, and web areas of hub. Head retaining nut for security and installation of washer and retaining ring. Access 5, 47				

"FOD REMINDER"

Check work area for tools and parts after completion of maintenance and inspection.

TM 55-1520-240-PM

PHASE NO. _____		Area Name and No. AFT ROTOR AND PYLON, AREA #6		Aircraft Serial No.	Date	
Inspect Phase No's	Inspection Requirements	Status	Faults and/or Remarks	Action Taken	Initial	
ALL/C	6.6 Aft rotary-wing head droop stops and interposer blocks (shroud removed and blades raised) for damage, wear, and security. Retorque fixed droop stop retaining bolts. Droop stop shrouds for security and damage. Refer to TM 55-1520-240-23. Access 5, 47					
ALL/C	6.7 Rotary-wing blade surfaces for delamination, unbonding, blisters, and cracks. Nose and erosion caps for cracks and unbonding. Trailing edge and trim tabs for cracks, twisting, and unbonding. Electrical lead bracket for damage and unbonding. Tip covers for damage and security. Root end composite pads (upper and lower) for unbonding or delamination. Lightning jumper strips for damage, proper bonding, and security. Shock absorber attachment brackets, including filament windings filler material, for cracks and voids. Refer to TM 55-1520-240-23. Access 5, 47					
ALL	6.8 Weather protective cover for chafing, cracks, and delamination. Attaching hardware for security. Adjacent fixed fairings for cracks and chafing. Access 5, 47					

"FOD REMINDER"

Check work area for tools and parts after completion of maintenance and inspection.

TM 55-1520-240-PM

PHASE NO. _____		Area Name and No. AFT ROTOR AND PYLON, AREA #6		Aircraft Serial No.	Date
Inspect Phase No's	Inspection Requirements	Status	Faults and/or Remarks	Action Taken	Initial
ALL/C	6.9 Pitch links (boots unzipped) for security, chafing, damage, corrosion, and proper installation of cotter pins and safety wire. Rod end bearings (upper and lower) for excessive radial play and liner unbonding. Pitch link boots for tears, damaged zipper, and security. Inspect for wear between pitch change link and pitch housing. Replace limiters. Access 5, 47				
ALL/C	6.10 Drive arms and collar for excessive wear at hinge points. Bearings for frayed or unbonded liners.				
ALL/C	6.11 Aft vertical shaft and bearing for leaks and signs of overheating. Housing mounts and adjacent structure for cracks, buckling, damage, and loose or missing hardware. Access 5, 47				
ALL/C	6.12 Visually inspect the aft vertical shaft at the top of the slider shaft for wear adjacent to the dust seal on the shaft and inspect for proper clearance of the dust seals.				

"FOD REMINDER"

Check work area for tools and parts after completion of maintenance and inspection.

TM 55-1520-240-PM

PHASE NO. _____		Area Name and No. AFT ROTOR AND PYLON, AREA #6		Aircraft Serial No.	Date
Inspect Phase No's	Inspection Requirements	Status	Faults and/or Remarks	Action Taken	Initial
ALL	6.17 Aft swashplate spherical ball bearing (uniball) for cleanliness and evidence of looseness. Mounting lugs for security and damage. Teflon bearings for contamination, unbonding and frayed edges.				
ALL	6.18 Aft slider shaft surface for flaking, peeling, and blistering of coating. Move thrust to full up position for inspection, then repeat inspection with thrust at full down position.				
ALL	6.19 Blade dampner bearings for looseness.				
ALL/C	6.20 Longitudinal cyclic trim link for security. Longitudinal cyclic trim actuator and connector for security. Actuator, link wire bundles, and rod ends for evidence of chafing.				
ALL/C	6.21 Longitudinal cyclic trim yoke for damage and corrosion. Inspect inside diameter of the aft yoke support shaft for corrosion. Yoke attaching hardware for security and evidence of looseness or wear. Access 47				

"FOD REMINDER"

Check work area for tools and parts after completion of maintenance and inspection.

TM 55-1520-240-PM

PHASE NO. _____		Area Name and No. AFT ROTOR AND PYLON, AREA #6		Aircraft Serial No.	Date
Inspect Phase No's	Inspection Requirements	Status	Faults and/or Remarks	Action Taken	Initial
ALL/C	6.22 Flight control bellcranks, connecting links, and idlers in pylon area for cracks and security. Connecting link swaged inserts for evidence of looseness. Access 5, 47				
ALL/C	6.23 Bellcrank supports in pylon area (STA 553.00 LH and STA 562.00 RH) and adjacent structure for security, excessive wear, and cracks. Access 5, 47				
ALL	6.24 Utility and flight boost cooling fans for security, corrosion, damage, and paint for chipping or peeling. Safety screens for dents, breaks, and security. Adjacent structure for damage, cracks, and corrosion. Access 43				
ALL	6.25 Power transfer unit for leakage and security. Access 7				
ALL/C	6.26 Flight boost power control module housing for cracks and damage. Mount structure for cracks and buckling. Access 7				
2, 4, C	6.27 Replace No. 2 boost pressure and return filter elements.				

"FOD REMINDER"

Check work area for tools and parts after completion of maintenance and inspection.

TM 55-1520-240-PM

PHASE NO. _____		Area Name and No.		Aircraft Serial No.	Date
		AFT ROTOR AND PYLON, AREA #6			
Inspect Phase No's	Inspection Requirements	Status	Faults and/or Remarks	Action Taken	Initial
ALL/C	6.28 Hydraulic reservoirs, coolers, and mount structure for cracks, buckling, and corrosion. Air ducts for security, cracks, and dents. Access 7, 51				
ALL	6.29 Hydraulic lines in pylon hydraulic compartment for leaks, chafing, and proper support. Access 7, 51				
ALL/C	6.30 Combining transmission housing, mount lugs, and mount hardware for loose or missing hardware, cracks, damage, and corrosion. Adjacent structure for buckling, damage, cracks, and loose or missing hardware. Access 40, 42				
ALL/C	6.31 Combining and engine transmission cooling fan exhaust duct for security, damage, and obstruction.				
ALL/C	6.32 Combining and engine transmission oil coolers for leaks, clogged or damaged core, and foreign objects. Cooler housing for cracks and corrosion. Transfer tubes for damage. Oil pressure switches/transducer for condition.				

"FOD REMINDER"

Check work area for tools and parts after completion of maintenance and inspection.

TM 55-1520-240-PM

PHASE NO. _____		Area Name and No. AFT ROTOR AND PYLON, AREA #6		Aircraft Serial No.	Date
Inspect Phase No's	Inspection Requirements	Status	Faults and/or Remarks	Action Taken	Initial
ALL/C	6.33 Combining and engine transmission main lube filters for extended warning indicators (3 places).				
ALL/C	6.34 Remove and inspect combining transmission main and aux oil filters and left and right debris detection screens.				
ALL/C	6.35 Remove and inspect No. 1 and No. 2 engine transmission oil filters and left and right debris detection screens.				
ALL	6.36 Engine transmission oil inlet screens and supports (left and right) for security and leakage. Access 42				
ALL	6.37 Electrical wiring and connectors in combining transmission area for security. Wiring for chafing and proper support. Insulation for cuts and fraying. Access 42				

"FOD REMINDER"

Check work area for tools and parts after completion of maintenance and inspection.

TM 55-1520-240-PM

PHASE NO. _____		Area Name and No. AFT ROTOR AND PYLON, AREA #6		Aircraft Serial No.	Date
Inspect Phase No's	Inspection Requirements	Status	Faults and/or Remarks	Action Taken	Initial
ALL/C	6.38 Work platforms, access doors, fairings and panels for damage, twisting, cracks, delamination, and corrosion. Latches and latch plates for condition, security, and closed latched. Seals and chafing strips for security and deterioration. Support cables and straps for wear, cuts, and fraying. Clam shell door latch pins for wear. Access 1, 2, 3, 4, 5, 6, 7, 8, 9, 40, 41, 42, 44, 45, 46, 47, 48, 49, 50, 51, 52, 56				
ALL/C	6.39 Aft pylon area for structural damage, skin cracks, dents, buckling, loose or missing rivets, and evidence of corrosion. Paint for chipping and peeling. Stencils and decals for condition.				
1, 3, C	6.40 Inspect and lubricate rod end bearings located in the aft pylon and aft fuselage.				
ALL/C	6.41 Replace combining transmission cooling fan drive shaft nonmetallic spline adapter (combining transmission adapter only).				

"FOD REMINDER"

Check work area for tools and parts after completion of maintenance and inspection.

TM 55-1520-240-PM

PHASE NO. _____		Area Name and No. FORWARD ROTOR, CROWN, AND TUNNEL, AREA #7		Aircraft Serial No.	Date
Inspect Phase No's	Inspection Requirements	Status	Faults and/or Remarks	Action Taken	Initial
ALL/C	FORWARD ROTOR, CROWN, AND TUNNEL, AREA #7 7.1 Tunnel area for debris under synch shafts. Shafts for scoring, chafing, and damage. Adapters and plates for cracks and security of hardware. Shock mounts for security and freedom of movement. Rubber for cuts, cracks or unbonding between rubber and metal parts, and evidence of contact with support brackets. Shock mount support bushings for wear. Bearings for evidence of overheating. Drain cups for debris. Support brackets for cracks, bending, and twisting. Retainer nuts for presence of cotter pin.				
ALL	7.2 Hydraulic lines in tunnel area for leaks, chafing and proper support.				
ALL/C	7.3 Flight control connecting links, idlers, and control arms throughout tunnel area for security, damage, corrosion, and evidence of interference. Connecting link swaged inserts for evidence of looseness. Access 34, 35, 36, 37, 38, 39.				

"FOD REMINDER"

Check work area for tools and parts after completion of maintenance and inspection.

TM 55-1520-240-PM

PHASE NO. _____		Area Name and No. FORWARD ROTOR, CROWN, AND TUNNEL, AREA #7		Aircraft Serial No.	Date
Inspect Phase No's	Inspection Requirements	Status	Faults and/or Remarks	Action Taken	Initial
ALL/C	7.4 Tunnel access covers for damage, cracks, twisting, delamination, and security. Latches and receptacle for looseness, wear, and proper operation. Seals for cuts, cracks, deterioration, and security. Support struts for security and loose or missing hardware. Access 34, 35, 36, 37, 38, 39				
ALL	7.5 Electrical wiring and connectors in tunnel area for security. Wiring for chafing and proper support. Insulation for cuts, cracks, and fraying. Access 30, 72				
ALL	7.6 Antennas and supports for damage, security and condition of electrical connectors.				
ALL	7.7 Flight boost power control module housing and support structure for cracks, damage, and buckling. Access 30, 72				
2, 4, C	7.8 Replace No. 1 flight boost pressure and return filter elements.				

"FOD REMINDER"

Check work area for tools and parts after completion of maintenance and inspection.

TM 55-1520-240-PM

PHASE NO. _____		Area Name and No. FORWARD ROTOR, CROWN, AND TUNNEL, AREA #7		Aircraft Serial No.	Date
Inspect Phase No's	Inspection Requirements	Status	Faults and/or Remarks	Action Taken	Initial
ALL	7.9 Flight control hydraulic reservoir, cooler, and mount structure for cracks, buckling, and corrosion. Cooler duct for security, cracks, and dents. Access 30, 31, 32, 72				
ALL	7.10 Cruise guide indicator signal conditioner for condition and security.				
ALL/C	7.11 Second stage mixing bellcranks, links, and support fittings for damage, corrosion, security, and evidence of interference. Control stops for security and damage. Access 72				
ALL	7.12 Electrical wiring and connectors in hydraulic compartment for security. Wiring for chafing and proper support. Insulation for cuts, cracks, and fraying. Access 30, 72				
ALL	7.13 Flight boost cooling fan for security, corrosion, and damage. Paint for chipping or peeling. Safety screen for dents, breaks, and security. Adjacent structure for damage, cracks, and corrosion. Access 30, 72				

"FOD REMINDER"

Check work area for tools and parts after completion of maintenance and inspection.

TM 55-1520-240-PM

PHASE NO. _____		Area Name and No. FORWARD ROTOR, CROWN, AND TUNNEL, AREA #7		Aircraft Serial No.	Date
Inspect Phase No's	Inspection Requirements	Status	Faults and/or Remarks	Action Taken	Initial
ALL/C	7.14 Flight boost power control module for leaks and security. Accumulator for proper precharge. Filter contamination and pump fault indicator for extended warning indicators.				
ALL	7.15 Power transfer unit for leakage and security.				
ALL	7.16 Hydraulic lines in forward transmission area for leaks, chafing, cracked or broken clamps, and proper support.				
ALL	7.17 Electrical wiring and connectors in forward transmission area for security. Wiring for chafing and proper support. Insulation for cuts, cracks, and fraying.				
ALL/C	7.18 Upper flight control connecting links and bellcranks between second stage and servocylinders for damage, corrosion, and security. Access 30, 72				

"FOD REMINDER"

Check work area for tools and parts after completion of maintenance and inspection.

TM 55-1520-240-PM

PHASE NO. _____		Area Name and No. FORWARD ROTOR, CROWN, AND TUNNEL, AREA #7		Aircraft Serial No.	Date
Inspect Phase No's	Inspection Requirements	Status	Faults and/or Remarks	Action Taken	Initial
ALL/C	7.19 First stage mixing bellcranks and links for damage, corrosion, security, and evidence of interference. Control stops for damage and security. Adjacent area for damage and foreign objects.				
ALL/C	7.20 First stage mixing complex supports and adjacent structure for buckling and cracks.				
ALL/C	7.21 Longitudinal cyclic trim link for security. Longitudinal cyclic trim actuator and connector for security. Actuator, link wire bundles, and rod ends for evidence of chafing. Access 30, 72				
ALL/C	7.22 Longitudinal cyclic trim yoke for damage and corrosion. Inspect forward yoke and inside diameter of the forward yoke shaft for corrosion. Yoke attaching hardware for security and evidence of looseness or wear. Access 30, 72				

"FOD REMINDER"

Check work area for tools and parts after completion of maintenance and inspection.

TM 55-1520-240-PM

PHASE NO. _____		Area Name and No. FORWARD ROTOR, CROWN, AND TUNNEL, AREA #7		Aircraft Serial No.	Date
Inspect Phase No's	Inspection Requirements	Status	Faults and/or Remarks	Action Taken	Initial
ALL/C	7.23 Forward transmission upper cover, mount lugs, mounting hardware, and adjacent structure for security, buckling, cracks, and corrosion. Transmission torque box structure for twisting, buckling, cracks, damage, and loose or missing rivets. Access 30, 72				
ALL/C	7.24 Upper boost servocylinders for leaks and security, chafing or interference with adjacent structure components. Support fittings for wear, damage, and cracks. Adjacent structure for cracks, buckling, and loose or missing rivets. Bearings and bushings for condition, radial and axial play.				
ALL/C	7.25 Drive arms and collar for excessive wear at hinge points. Bearings for frayed or unbonded liners. Access 30, 72				
ALL	7.26 Forward transmission oil cooler mount flanges for cracks. Hardware for security. Access 30, 72				

"FOD REMINDER"

Check work area for tools and parts after completion of maintenance and inspection.

TM 55-1520-240-PM

PHASE NO. _____		Area Name and No. FORWARD ROTOR, CROWN, AND TUNNEL, AREA #7		Aircraft Serial No.	Date
Inspect Phase No's	Inspection Requirements	Status	Faults and/or Remarks	Action Taken	Initial
ALL/C	7.27 Inspect forward transmission oil cooler impeller installation. Refer to TM 55-1520-240-23.				
ALL/C	7.28 Remove and inspect forward transmission synch shaft adapter.				
ALL/C	7.29 Forward transmission cooling fan (inlet duct removed) for cracks, nicks, and damage or corrosion of impeller, diffuser, or housing. Impeller for evidence of tip rub.				
ALL/C	7.30 Remove and inspect forward transmission main and aux oil filters and debris detection screens.				
ALL	7.31 Forward transmission cooler air inlet (behind STA 120.00) for cleanliness and foreign objects. Entire compartment for debris.				

"FOD REMINDER"

Check work area for tools and parts after completion of maintenance and inspection.

TM 55-1520-240-PM

PHASE NO. _____		Area Name and No. FORWARD ROTOR, CROWN, AND TUNNEL, AREA #7		Aircraft Serial No.	Date
Inspect Phase No's	Inspection Requirements	Status	Faults and/or Remarks	Action Taken	Initial
ALL/C	7.32 Forward rotary-wing head for corrosion, damage, and cracks in pitch-varying housing, pitch shaft, and web areas of hub. Head retaining nut for security and installation of washer and retaining ring. Access 30, 72				
2, 4, C	7.33 Drain and service all rotary-wing head reservoirs.				
ALL/C	7.34 Check forward rotary-wing head retaining nut for specified torque. Refer to TM 55-1520-240-23.				
ALL/C	7.35 Inspect the installed horizontal hinge pins and bearings per TM 55-1520-240-23.				
ALL/C	7.35.1 Perform eddy current inspection of area surrounding the vertical web lightening holes on rotor hubs that contain such lightening holes.				
ALL/C	7.36 Forward rotary-wing head droop stops (blades raised) for damage, wear, and security. Retorque fixed droop stop retaining bolts. Access 30, 72				

"FOD REMINDER"

Check work area for tools and parts after completion of maintenance and inspection.

2-51 Change 1

TM 55-1520-240-PM

PHASE NO. _____		Area Name and No. FORWARD ROTOR, CROWN, AND TUNNEL, AREA #7		Aircraft Serial No.	Date
Inspect Phase No's	Inspection Requirements	Status	Faults and/or Remarks	Action Taken	Initial
ALL/C	7.37 Rotary-wing blade surfaces for delamination, unbonding, blisters, and cracks. Nose and erosion caps for cracks and unbonding. Trailing edge and trim tabs for cracks, twisting, and unbonding. Electrical lead wire brackets for damage and unbonding. Tip covers for damage and security. Root end composite pads (upper and lower) for unbonding or delamination. Lightning jumper strips for damage, proper bonding, and security. Shock absorber attachment brackets, including filament windings filler material, for cracks and voids. Refer to TM 55-1520-240-23. Access 30, 72				
ALL	7.38 Weather protective cover for chafing, cracks, and delamination. Attaching hardware for security. Adjacent fixed fairings for cracks and chafing. Access 30, 72				

"FOD REMINDER"

Check work area for tools and parts after completion of maintenance and inspection.

TM 55-1520-240-PM

PHASE NO. _____		Area Name and No. FORWARD ROTOR, CROWN, AND TUNNEL, AREA #7		Aircraft Serial No.	Date
Inspect Phase No's	Inspection Requirements	Status	Faults and/or Remarks	Action Taken	Initial
ALL/C	7.39 Pitch links (boots unzipped) for security, chafing, damage, corrosion, and proper installation of cotter pins and safety wire. Rod end bearings (upper and lower) for excessive radial play and liner unbonding. Pitch link boots for tears, damaged zipper, and security. Inspect for wear between pitch change link and pitch housing. Replace limiters. Access 30, 72				
ALL/C	7.40 Visually Inspect forward vertical shaft at top of slider for wear adjacent to dust seal on shaft and inspect for proper clearance of dust seals.				
ALL	7.41 Forward transmission fairing work platform, access doors, and panels for damage, twisting, cracks, delamination, and corrosion. Latches and latch plates for condition, security, and closed and latched. Seals and chafing strips for security and deterioration. Support cables and straps for wear, cuts, and fraying. Access 30, 72				

"FOD REMINDER"

Check work area for tools and parts after completion of maintenance and inspection.

TM 55-1520-240-PM

PHASE NO. _____		Area Name and No. FORWARD ROTOR, CROWN, AND TUNNEL, AREA #7		Aircraft Serial No.	Date
Inspect Phase No's	Inspection Requirements	Status	Faults and/or Remarks	Action Taken	Initial
ALL/C	7.42 Entire area for structural damage, skin cracks, dents, buckling, loose or missing rivets, and evidence of corrosion. Paint for chipping and peeling. Stencils and decals for condition.				
1, 3	7.43 Inspect and lubricate rod end bearings located in the fwd rotor, crown, and tunnel area.				
ALL	7.44 Swashplate for signs of damage, overheating, and accumulation of grease. Using a flashlight or other suitable light source, visually inspect with a mirror or flexible borescope the area between the underside of the rotating ring and stationary ring for any slinging or clumping or grease/debris (i.e., seal, bearing cage, seal spring, wire, or other material). A thin bead of grease around the sealing area is considered normal.				

"FOD REMINDER"

Check work area for tools and parts after completion of maintenance and inspection.

TM 55-1520-240-PM

PHASE NO. _____		Area Name and No. FORWARD ROTOR, CROWN, AND TUNNEL, AREA #7		Aircraft Serial No.	Date
Inspect Phase No's	Inspection Requirements	Status	Faults and/or Remarks	Action Taken	Initial
ALL	7.45 Forward swashplate spherical ball bearings (uniball) for cleanliness and evidence of looseness. Mounting lugs for security and damage. Teflon bearings for contamination, unbonding and frayed edges.				
ALL	7.46 Forward slider shaft surface for flaking, peeling, and blistering of coating. Move thrust to full up position for inspection, then repeat inspection with thrust in full down position.				
ALL	7.47 Blade dampner bearings for looseness.				

"FOD REMINDER"

Check work area for tools and parts after completion of maintenance and inspection.

TM 55-1520-240-PM

PHASE NO. _____		Area Name and No. RAMP AREA #8		Aircraft Serial No.	Date
Inspect Phase No's	Inspection Requirements	Status	Faults and/or Remarks	Action Taken	Initial
	RAMP AREA #8				
ALL	8.1 APU installation for security of components and loose or missing hardware. Drain lines for obstructions. APU housing, covers, and brackets for cracks, dents, and deformation. Refer to TM 55-2835-205-23.				
ALL/C	8.2 Drain and reservice APU oil sump. Refer to TM 55-2835-205-23.				
ALL/C	8.3 Replace APU oil filter element and external (inlet) fuel filter. Refer to TM 55-2835-205-23.				
2, 4, C	8.4 Remove, inspect, clean, and reinstall APU fuel (strainer) filter. Refer to TM 55-2835-205-23.				
ALL	8.5 APU air inlet screen and exhaust for obstruction. Refer to TM 55-2835-205-23.				

"FOD REMINDER"

Check work area for tools and parts after completion of maintenance and inspection.

TM 55-1520-240-PM

PHASE NO. _____		Area Name and No. RAMP AREA #8		Aircraft Serial No.	Date
Inspect Phase No's	Inspection Requirements	Status	Faults and/or Remarks	Action Taken	Initial
ALL	8.6 Ramp and cargo door for twisting, damage, security of fittings, seal deterioration, cracks, and corrosion. Cargo door for proper manual operation.				
1, 3	8.7 Jettisonable cargo door for ease of release. Mechanism for cracks, wear, twisting, and security. At reinstallation, locking mechanisms for secure engagement, handle for closed and latched position and proper safety. Refer to TM 55-1520-240-T.				
ALL	8.8 Ramp and cargo door coaming for damage, cracks, delamination, and security.				
ALL	8.9 Cargo loading ramp extensions for twist, cracks, and security. Attaching hardware for security.				
ALL	8.10 APU start module for leaks, security of mounting, components, and electrical connector. Mount structure for buckling and cracks.				
ALL/C	8.11 Aft transmission oil cooler housing and mounts for cracks and security.				

"FOD REMINDER"

Check work area for tools and parts after completion of maintenance and inspection.

TM 55-1520-240-PM

PHASE NO. _____		Area Name and No. RAMP AREA #8		Aircraft Serial No.	Date
Inspect Phase No's	Inspection Requirements	Status	Faults and/or Remarks	Action Taken	Initial
ALL/C	8.12 Remove and inspect aft transmission main and aux oil filters and debris detection screen.				
ALL	8.13 Aft transmission access door fasteners for proper operation and security.				
ALL/C	8.14 Aft transmission cooling fan (duct removed), impeller, and vanes for nicks, cracks, corrosion, and security. Exhaust duct for cracks, chafing, and damage.				
ALL/C	8.15 Remove and inspect aft transmission input shaft adapter and plates for security, cracks, and damage. Hardware for security.				

"FOD REMINDER"

Check work area for tools and parts after completion of maintenance and inspection.

TM 55-1520-240-PM

PHASE NO. _____		Area Name and No. RAMP AREA #8		Aircraft Serial No.	Date
Inspect Phase No's	Inspection Requirements	Status	Faults and/or Remarks	Action Taken	Initial
ALL/C	8.16 Aft synch shafts for chafing, scoring, and damage. Adapters and plates for cracks and security of hardware. Shock mounts for security and freedom of movement. Rubber for cuts or cracks, unbonding between rubber and metal parts, and evidence of contact with support brackets. Shock mount support bushings for wear. Bearing for evidence of overheating. Support bracket for cracks, bending, and twisting. Retainer nut for presence of cotter pin.				
ALL/C	8.17 Aft transmission upper cover, mount lugs, and mounting hardware for security, cracks, and corrosion.				
ALL/C	8.18 Aft transmission support structure between stations STA 575.00, RBL 8.00. LBL 8.00 and STA 534.00, RBL 8.00 and LBL 8.00 for twisting, buckling, cracks, damage, and loose or missing rivets.				
ALL	8.19 Aft transmission drip pan for condition.				

"FOD REMINDER"

Check work area for tools and parts after completion of maintenance and inspection.

TM 55-1520-240-PM

PHASE NO. _____		Area Name and No. RAMP AREA #8		Aircraft Serial No.	Date
Inspect Phase No's	Inspection Requirements	Status	Faults and/or Remarks	Action Taken	Initial
ALL	8.20 No. 2 Flight boost hydraulic pump and hoses for leaks.				
ALL	8.21 Utility hydraulic pump and hoses for leaks.				
ALL	8.22 APU start accumulator housing, manifold, and mount fitting for leaks, damage, cracks, and security. Adjacent structure for buckling and cracks.				
ALL	8.23 Transmission mounted generators (left and right) for security of mounting, loose or missing hardware, and evidence of oil leaks. Wiring for security of attachment and evidence of chafing. Terminal covers for cracking and proper installation.				
ALL	8.24 Utility hydraulic pressure control module housing for leakage. Mount structure for cracks, buckling, and damage.				
2, 4, C	8.25 Replace utility system pressure and return elements.				
ALL	8.26 APU electronic control unit and mount for condition and security. Electrical wiring and connectors for damage, chafing and security.				

"FOD REMINDER"

Check work area for tools and parts after completion of maintenance and inspection.

TM 55-1520-240-PM

PHASE NO. _____		Area Name and No. RAMP AREA #8		Aircraft Serial No.	Date
Inspect Phase No's	Inspection Requirements	Status	Faults and/or Remarks	Action Taken	Initial
ALL	8.27 Troop alarm arm bell and lights for condition and security.				
ALL	8.28 Utility hydraulic return module housing, mount structure, and transfer cylinder for leakage, cracks, buckling, and damage.				
ALL/C	8.29 Flight control links and bellcranks throughout the aft cabin area for security, damage, and corrosion. Connecting link swaged inserts for evidence of looseness.				
ALL	8.30 Fire bottles for pressure and wire connectors. System tubing for security and condition.				
ALL/C	8.31 Bellcrank supports at STA 534.00 (left and right) and adjacent structure for security, corrosion, and cracks.				
ALL	8.32 Fuel and crossfeed valves and hoses for condition and security.				
ALL	8.33 Inspect P3 drain cartridge plastic tube (LH and RH) for cracks, security, and broken or missing hardware. (With 74)				

"FOD REMINDER"

Check work area for tools and parts after completion of maintenance and inspection.

TM 55-1520-240-PM

PHASE NO. _____		Area Name and No. RAMP AREA #8		Aircraft Serial No.	Date
Inspect Phase No's	Inspection Requirements	Status	Faults and/or Remarks	Action Taken	Initial
ALL/C	8.34 Power steering and swivel lock module for leaks and security of components and connectors. Mount structure for cracks and buckling.				
ALL	8.35 Ramp control valve, sequence valve, pressure actuated valve, and ramp actuators for security, leaks, and damage.				
ALL	8.36 Hydraulic fill module for leaks and security. Pump and linkage for condition. Filler filter for cleanliness and condition. Filler cap for positive closure.				
ALL	8.37 Utility hydraulic hand pump for leaks, cracks, and security of mountings. Mount hardware and structure for cracks, buckling, and security. Pump handle and linkage for security and excessive wear.				

"FOD REMINDER"

Check work area for tools and parts after completion of maintenance and inspection.

TM 55-1520-240-PM

PHASE NO. _____		Area Name and No. RAMP AREA #8		Aircraft Serial No.	Date
Inspect Phase No's	Inspection Requirements	Status	Faults and/or Remarks	Action Taken	Initial
ALL/C	8.38 Main structural formers and longerons throughout area for distortion, cracks, damage, corrosion, and loose or missing fasteners. In the formers at STA 482.00, 534.00, and 594.00 look particularly for cracks in the upper caps from the aft transmission mount deck down to and including splice with the side cap, the splice angles at STA 594.00, and the forward engine mount and adjacent structure.				
ALL	8.39 Electrical wiring and connectors throughout the area for security. Wiring for chafing, proper support, cuts, cracks, and fraying of insulation.				
ALL	8.40 Flooring removed. Structure under floor, floor panels, and floor beams for cracks, corrosion and deterioration of finish.				
ALL	8.41 Inspect ramp 5,000 pound tie-downs for serviceability IAW TM 55-1520-240-23 .				

"FOD REMINDER"

Check work area for tools and parts after completion of maintenance and inspection.

TM 55-1520-240-PM

PHASE NO. _____		Area Name and No. CABIN AREA #9		Aircraft Serial No.	Date
Inspect Phase No's	Inspection Requirements	Status	Faults and/or Remarks	Action Taken	Initial
	CABIN AREA #9				
ALL	9.1 Floor panels and cargo tiedown fittings for damage, bending, twisting, cleanliness, corrosion, and security.				
ALL	9.2 Flooring removed, structure under floor, floor panels, and floor beams for cracks, corrosion, and deterioration of finish. Floor vibration isolators for deterioration and condition.				
ALL	9.3 Heater outlets for obstructions.				
ALL	9.4 Heater ducts and outlets above and below floor for cracks and security.				
ALL	9.5 Buffer boards for damage and security.				
ALL	9.6 Transformer-rectifier air inlets (left and right) for obstructions.				
ALL	9.7 Troop seat structure for damage and security. Quick release latches for proper operation. Fabric for cleanliness and condition. Seat belts for damage, fraying, corrosion, cuts, cleanliness, security.				

"FOD REMINDER"

Check work area for tools and parts after completion of maintenance and inspection.

TM 55-1520-240-PM

PHASE NO. _____		Area Name and No. CABIN AREA #9		Aircraft Serial No.	Date
Inspect Phase No's	Inspection Requirements	Status	Faults and/or Remarks	Action Taken	Initial
ALL	9.8 No. 1 and No. 2 Digital Engine Control Units (DECU) for condition and security. Cables for damage, chafing, cuts, corrosion and security. (With 74)				
ALL	9.9 Hoist control grip and cable for damage, chafing, security of connector, and proper stowage.				
ALL	9.10 Acoustic blankets throughout the area for security, condition and cleanliness.				
ALL	9.11 Main, side and crown formers for buckling, cracks, damage, corrosion, and loose or missing fasteners.				
ALL	9.12 Electrical wiring, components and connectors throughout cabin area for security. Wiring for chafing and proper support. Insulation for cuts, cracks, and fraying.				
ALL	9.13 Cabin windows for security, cracks, and cleanliness. Seals for deterioration, cuts, cracks, and security.				

"FOD REMINDER"

Check work area for tools and parts after completion of maintenance and inspection.

TM 55-1520-240-PM

PHASE NO. _____		Area Name and No. CABIN AREA #9	Aircraft Serial No.	Date	
Inspect Phase No's	Inspection Requirements	Status	Faults and/or Remarks	Action Taken	Initial
ALL	9.14 Rescue hoist support structure for damage.				
ALL	9.15 Rescue hatch upper and lower doors for cracks, damage, corrosion, cleanliness, and loose or missing rivets. Seals for deterioration, cuts, cracks, and security. Lower door actuating and latching mechanism for damage, security, and freedom of operation. Lower door actuator (gear box) for freedom of operation. Latches for security and proper operation.				
ALL	9.16 Hand crank and cargo hook loading pole for proper stowage and condition.				
ALL/C	9.17 Center external cargo hook for cleanliness, leaks, corrosion, and cracks. Mount fitting for freedom of movement. Emergency release solenoid for security.				
ALL/C	9.18 Inspect center cargo hook support beam and bearings.				

"FOD REMINDER"

Check work area for tools and parts after completion of maintenance and inspection.

TM 55-1520-240-PM

PHASE NO. _____		Area Name and No. CABIN AREA #9		Aircraft Serial No.	Date
Inspect Phase No's	Inspection Requirements	Status	Faults and/or Remarks	Action Taken	Initial
ALL/C	9.19 Functionally test forward, center, and aft cargo hook manual release mechanism. Reset center hook. Manual release mechanism for wear, proper rigging, cable fraying, chafing, damage, and security. Refer to TM 55-1520-240-T.				
ALL	9.20 Cabin entrance door, including step for damage and security. Safety catch for proper operation. Seal for deterioration and security. Tracks and rollers for wear, roughness, damage, and cleanliness.				
ALL	9.21 Emergency escape axe stowed.				
ALL	9.22 Paratroop anchor line assembly for broken wires and bends. Fittings and hardware for wear, cracks, and security. Attaching structure for cracks, dents, and buckling. If not installed, ensure proper stowage.				
ALL/C	9.23 Suppressive fire system (M-24) support brackets and adjacent structure for cracks, wear, damage, corrosion, and security.				

"FOD REMINDER"

Check work area for tools and parts after completion of maintenance and inspection.

TM 55-1520-240-PM

PHASE NO. _____		Area Name and No. CABIN AREA #9		Aircraft Serial No.	Date
Inspect Phase No's	Inspection Requirements	Status	Faults and/or Remarks	Action Taken	Initial
ALL	9.24 Cabin escape panel (LEFT AND RIGHT) for security of release mechanism, cracks, twists, and corrosion. Seals for cuts, cracks, and security.				
ALL	9.25 Troop alarm bell and lights for condition and security.				
ALL	9.26 EAPS control boxes for security, condition, and electrical connectors for proper installation.				
ALL	9.27 Inspect cabin floor tie-downs for serviceability IAW TM 55-1520-240-23.				

"FOD REMINDER"

Check work area for tools and parts after completion of maintenance and inspection.

TM 55-1520-240-PM

PHASE NO. _____		Area Name and No. COCKPIT AREA #10		Aircraft Serial No.	Date
Inspect Phase No's	Inspection Requirements	Status	Faults and/or Remarks	Action Taken	Initial
	COCKPIT AREA #10				
ALL	10.1 Winch cable cutter pulley assembly for corrosion and damage. Nuts and bolts for tightness.				
ALL	10.2 Winch hook and cable assembly for corrosion. Hook for easy swivel. Safety latch for security. Cable for broken strands or fraying. Quick disconnect and guard for damage and security.				
ALL	10.3 Winch tackle blocks for corrosion and loose fittings. Quick release pins for freedom of motion. Refer to TM 55-1520-240-T.				
ALL	10.4 Cargo winch control valves, pressure reducer, and tubes and hoses for leaks, security, and damage. Winch motor and brake actuator for leaks and security.				
ALL	10.5 Heater compartment structure including winch support structure, for cracks, damage, corrosion, and loose or missing fasteners.				

"FOD REMINDER"

Check work area for tools and parts after completion of maintenance and inspection.

TM 55-1520-240-PM

PHASE NO. _____		Area Name and No. COCKPIT AREA #10	Aircraft Serial No.	Date	
Inspect Phase No's	Inspection Requirements	Status	Faults and/or Remarks	Action Taken	Initial
ALL	10.6 Heater ducts and outlets above and below floor for cracks and security.				
ALL	10.7 Heater fuel lines for chafing, damage, security, and proper support. Heater exhaust stack for indication of overheating, security, and damage. Heater drain lines for obstruction.				
ALL	10.8 Flooring removed, structure under floor, floor panels, and floor beams for cracks, corrosion, and deterioration of finish.				
ALL	10.9 Electrical wiring and connectors in heater compartment for security. Wiring for chafing, proper support, and condition of insulation. Terminal board for condition and proper installation of covers.				
ALL	10.10 Avionics compartment structure for damage, cracks, distortion, corrosion, and loose or missing fasteners.				
ALL/C	10.11 Cockpit transfer bellcranks for security, corrosion, and damage.				

"FOD REMINDER"

Check work area for tools and parts after completion of maintenance and inspection.

TM 55-1520-240-PM

PHASE NO. _____		Area Name and No. COCKPIT AREA #10		Aircraft Serial No.	Date
Inspect Phase No's	Inspection Requirements	Status	Faults and/or Remarks	Action Taken	Initial
ALL/C	10.12 Pallet mounted dampers, actuators, links, linear variable differential transducers (LVDTs), springs, spring capsules, detent capsule, and droop potentiometer for security, evidence of interference, and damage. Structural pallets for security, delamination, damage, and threaded inserts that are displaced from their normal position. Electrical connectors and wiring for security and chafing.				
ALL	10.13 Dynamic absorbers for security. Support structure for distortion, cracks, and loose or missing hardware.				
ALL/C	10.14 Dash actuator and connectors for security.				
ALL/C	10.15 Flight control links in lower closet area for damage, corrosion, cracks, and security. Inspect yaw, thrust, roll, and pitch ILCA intermediate connecting links for cracks or displaced bearings.				

"FOD REMINDER"

Check work area for tools and parts after completion of maintenance and inspection.

TM 55-1520-240-PM

PHASE NO. _____		Area Name and No. COCKPIT AREA #10		Aircraft Serial No.	Date
Inspect Phase No's	Inspection Requirements	Status	Faults and/or Remarks	Action Taken	Initial
ALL/C	10.16 Integrated lower control actuator (ILCA) for leaks, cracks, and security of components. Linkage for security. ILCA area for evidence of interference and for foreign objects.				
2, 4, C	10.16.1 Remove uncirculated fluid from extensible link of each ILCA by purging three ounces of hydraulic fluid from number one and number two sides of the roll, pitch, and yaw ILCA link bleed ports.				
ALL/C	10.17 Intermediate flight control bellcranks and associated links for security, cracks, nicks, dents, damage, corrosion and wear. Structural supports for wear and buckling.				
ALL/C	10.18 First stage mixing bellcranks and links for nicks, cracks, dents, damage, corrosion, and evidence of interference. Control stops for security and damage. Adjacent area for foreign objects.				
ALL/C	10.19 First stage mixing complex supports and adjacent structure for buckling and cracks.				

"FOD REMINDER"

Check work area for tools and parts after completion of maintenance and inspection.

TM 55-1520-240-PM

PHASE NO. _____		Area Name and No. COCKPIT AREA #10		Aircraft Serial No.	Date
Inspect Phase No's	Inspection Requirements	Status	Faults and/or Remarks	Action Taken	Initial
ALL/C	10.20 Lower control modules (2 places) for leaks and security of mounting and connectors.				
ALL	10.21 Electrical wiring and connectors in flight control closet for security. Wiring for evidence of chafing, proper support, insulation cracks, and cuts and fraying. Terminal boards for chips, cracks, cleanliness, and proper installation of covers.				
1, 3	10.22 Inspect and lubricate rod end bearings located in flight control closet.				
ALL	10.23 Troop commander's seat and structure for security and damage. Seat belt for wear, fraying, and oil soaking.				
ALL/C	10.24 Forward transmission oil cooler (drip pan removed) for leaks and security of components and hardware.				
ALL	10.25 No. 1 Flight boost hydraulic pump and hoses for leaks.				

"FOD REMINDER"

Check work area for tools and parts after completion of maintenance and inspection.

TM 55-1520-240-PM

PHASE NO. _____		Area Name and No. COCKPIT AREA #10		Aircraft Serial No.	Date
Inspect Phase No's	Inspection Requirements	Status	Faults and/or Remarks	Action Taken	Initial
ALL	10.26 Forward transmission torque box structure for buckling, cracks, damage, corrosion, and loose or missing rivets.				
ALL/C	10.27 Forward transmission main lube filter for extended warning indicator.				
ALL	10.28 Pilot's and copilot's safety belts and harness for damage, corrosion, fraying, cuts, oil soaking, security.				
ALL/C	10.29 Pilot's and copilot's shoulder harness inertia reels for security and proper operation.				
ALL	10.30 Pilot's and copilot's seat adjustment mechanisms for wear, cleanliness, security, and ease of operation. Pay particular attention to forward adjustment handle carriage bearing bracket.				
ALL	10.31 Pilot's and copilot's seat upholstery and cushions for security, cleanliness, wear, tears, and cuts.				

"FOD REMINDER"

Check work area for tools and parts after completion of maintenance and inspection.

TM 55-1520-240-PM

PHASE NO. _____		Area Name and No. COCKPIT AREA #10		Aircraft Serial No.	Date
Inspect Phase No's	Inspection Requirements	Status	Faults and/or Remarks	Action Taken	Initial
ALL	10.32 Pilot's and copilot's seat structure for cracks, dents, bends, and security. Seat tracks for security, cleanliness, cracks, twisting, and dents.				
ALL	10.33 Pilot's and copilot's seat armor for installation and operation.				
ALL	10.34 Windshield and cockpit windows for cracks, delamination, crazing, scratches, and discoloration.				
ALL	10.35 Heater and defroster ducts for cracks, security, and obstructions. Controls for freedom of operation.				
ALL/C	10.36 Pilot's and copilot's flight control connecting links, idlers, and bellcranks under cockpit floor (access panels removed) for damage, cracks, dents, corrosion, worn bearings, security.				
ALL/C	10.37 Pilot's and copilot's control pedals, control sticks, and thrust levers for loose hardware, cracks, and security.				

"FOD REMINDER"

Check work area for tools and parts after completion of maintenance and inspection.

TM 55-1520-240-PM

PHASE NO. _____		Area Name and No. COCKPIT AREA #10		Aircraft Serial No.	Date
Inspect Phase No's	Inspection Requirements	Status	Faults and/or Remarks	Action Taken	Initial
ALL	10.38 Pilot's and copilot's brake cylinders for leaks and security. Brake hose for leaks and proper routing.				
ALL	10.39 Left power distribution panel (opened) for security of components and loose or missing hardware. Wiring and connections for damage, security, chafing, and proper support. Wiring insulation for cuts, cracks, and fraying. Inspect all left PDP circuit breakers for evidence of water/moisture, arcing/burning, and circuit breaker terminal studs/hardware for evidence of corrosion/salt.				
ALL	10.40 Instrument range marks for accuracy and legibility. Refer to TM 1-1520-240-10. Instruments lenses for cracks, cleanliness, looseness, and slippage marks (if required). Instruments for security and proper position. Knobs for security and damage.				
ALL	10.41 Perform inspection of pitot-static system.				

"FOD REMINDER"

Check work area for tools and parts after completion of maintenance and inspection.

TM 55-1520-240-PM

PHASE NO. _____		Area Name and No. COCKPIT AREA #10		Aircraft Serial No.	Date
Inspect Phase No's	Inspection Requirements	Status	Faults and/or Remarks	Action Taken	Initial
ALL/C	10.42 Inspect and test OAT/FAT gage. Refer to TM 1-1500-204-23.				
1, 3	10.43 Inspect and test altimeters. Refer to TM 1-1500-204-23.				
1, 3	10.44 Test accuracy of speed indicators. Refer to TM 1-1500-204-23.				
ALL	10.45 Overhead panel (lowered) for security of components and loose or missing hardware. Wiring and connections for damage, security, chafing, corrosion, proper support. Wiring insulation for cuts, cracks and fraying. Adjacent structure for cracks, damage, corrosion.				
ALL	10.46 Remove soundproofing blanket from upper forward areas STA 95.00 bulkhead. Inspect structure for cracks in area from top of companion way to ceiling and between LBL 30.00 and RBL 30.00.				

"FOD REMINDER"

Check work area for tools and parts after completion of maintenance and inspection.

TM 55-1520-240-PM

PHASE NO. _____		Area Name and No. COCKPIT AREA #10		Aircraft Serial No.	Date
Inspect Phase No's	Inspection Requirements	Status	Faults and/or Remarks	Action Taken	Initial
ALL	10.47 Right power distribution panel (opened) for security of components and loose or missing hardware. Wiring and connections for damage, security. Inspect all right PDP circuit breakers for evidence of water/moisture, arcing/burning, and circuit breaker terminal studs/hardware for evidence of corrosion/salt.				

"FOD REMINDER"

Check work area for tools and parts after completion of maintenance and inspection.

TM 55-1520-240-PM

PHASE NO. _____		Area Name and No. POWER ON CHECKS		Aircraft Serial No.	Date
Inspect Phase No's	Inspection Requirements	Status	Faults and/or Remarks	Action Taken	Initial
	POWER ON CHECKS				
	<div style="border: 1px solid black; padding: 2px; display: inline-block;">WARNING</div> Before performing each power on check, make sure all personnel and equipment are clear of the system(s) being tested. The aircraft must be clear of all obstructions or injury to personnel or damage to aircraft may result.				
ALL	P.1 Perform a preventive maintenance daily (PMD) IAW TM 55-1520-240-PMD prior to conducting power checks.				
ALL	P.2 Perform DC power system operational check. Refer to TM 55-1520-240-T.				
ALL/C	P.3 APU (running). Electrical and hydraulic power applied. Check APU for fuel and oil leaks.				
ALL/C	P.4 Maintenance panel for proper pressure and temperature indications, PUMP FAULT lights off, GROUND CONTACT lights (if installed) on.				

"FOD REMINDER"

Check work area for tools and parts after completion of maintenance and inspection.

TM 55-1520-240-PM

PHASE NO. _____		Area Name and No. POWER ON CHECKS		Aircraft Serial No.	Date
Inspect Phase No's	Inspection Requirements	Status	Faults and/or Remarks	Action Taken	Initial
ALL/C	P.5 Set maintenance panel GND switch to test and check indicators for proper operation. Set switch to RESET and check indicators for reset position. Press to test caution lights. Verify all corresponding caution/master caution lights illuminate.				
ALL	P.6 Cabin dome lights (4 places) and ramp light for operation and cracked or broken lenses.				
ALL/C	P.7 Overhead panel and center console lights for proper operation.				
ALL/C	P.8 Instrument lights on pilot's, copilot's, and center instrument panels for proper operation.				
ALL	P.9 Cockpit flood lights, dome lights, and utility lights for proper operation.				
ALL/C	P.10 Landing lights for proper operation.				
ALL/C	P.11 Navigation lights (left, aft, and right) for proper operation.				

"FOD REMINDER"

Check work area for tools and parts after completion of maintenance and inspection.

TM 55-1520-240-PM

PHASE NO. _____		Area Name and No. POWER ON CHECKS		Aircraft Serial No.	Date
Inspect Phase No's	Inspection Requirements	Status	Faults and/or Remarks	Action Taken	Initial
ALL/C	P.12 Anticollision lights (upper and lower) for proper operation.				
ALL/C	P.13 Battery charger maintenance lights in left electrical pod. CHARGE COMPLETE light should be on.				
ALL	P.14 Perform functional test of pitot tubes and AFCS sideslip (yaw) port heaters. Refer to TM 55-1520-240-T.				
ALL/C	P.15 Inter-tank fuel system tubes, hoses, fittings, and connections in left pod interior (access cover removed) for leaks (FUEL PUMPS ON), chafing, damage, and proper support. Access 62, 63, 66				
ALL/C	P.16 Perform functional test of forward, center, and aft cargo hooks normal release mode. Verify operation of indicating lights on dual hook relay box. Refer to TM 55-1520-240-T.				

"FOD REMINDER"

Check work area for tools and parts after completion of maintenance and inspection.

TM 55-1520-240-PM

PHASE NO. _____		Area Name and No. POWER ON CHECKS		Aircraft Serial No.	Date
Inspect Phase No's	Inspection Requirements	Status	Faults and/or Remarks	Action Taken	Initial
ALL	P.17 Perform functional test of emergency cargo hook release system on cargo hooks. Replenish air charge in center hook as required. Refer to TM 55-1520-240-T.				
ALL	P.18 Perform functional test of DUAL HOOK FAULT caution lights. Refer to TM 55-1520-240-T.				
ALL/C	P.19 Inter-tank fuel system tubes, hoses, fittings, and connections in the right pod interior (access cover removed) for leaks (FUEL PUMPS ON), chafing, damage, and proper support. Access 19, 21, 24				
ALL/C	P.20 Perform operational check of aft vertical drive shaft chip detector. Refer to TM 55-1520-240-T. Access 5, 47				
ALL/C	P.21 Perform operational check of combining transmission chip detector and debris screens (left and right). Refer to TM 55-1520-240-T. Access 40, 42				

"FOD REMINDER"

Check work area for tools and parts after completion of maintenance and inspection.

TM 55-1520-240-PM

PHASE NO. _____		Area Name and No. POWER ON CHECKS	Aircraft Serial No.	Date	
Inspect Phase No's	Inspection Requirements	Status	Faults and/or Remarks	Action Taken	Initial
ALL	P.22 Perform functional test of combining and engine transmission XMSN OIL HOT caution light system. Refer to TM 55-1520-240-T. Access 40, 42				
ALL	P.23 Perform functional test of combining and engine transmission oil pressure caution light system (main and aux). Refer to TM 55-1520-240-T. Access 40, 42				
ALL	P.24 Perform operational check of engine transmission debris screens (left and right). Refer to TM 55-1520-240-T. Access 40, 42				
ALL	P.25 Perform operational check of aft transmission debris screen and chip detector. Refer to TM 55-1520-240-T.				
ALL	P.26 Perform functional test of aft XMSN OIL HOT caution light system. Refer to TM 55-1520-240-T.				
ALL	P.27 Perform functional test of aft transmission oil pressure caution light system (main and aux). Refer to TM 55-1520-240-T. Access 72				

"FOD REMINDER"

Check work area for tools and parts after completion of maintenance and inspection.

TM 55-1520-240-PM

PHASE NO. _____		Area Name and No. POWER ON CHECKS	Aircraft Serial No.	Date	
Inspect Phase No's	Inspection Requirements	Status	Faults and/or Remarks	Action Taken	Initial
ALL	P.28 Perform functional test of engine fuel shutoff valves and valve caution lights. Refer to TM 55-1520-240-T.				
ALL	P.29 Perform functional test of fuel crossfeed valves and valve caution lights. Refer to TM 55-1520-240-T.				
ALL	P.30 Fuel system hose, tubes, fittings, and fuel flow transmitters in aft cabin and ramp areas for leaks (FUEL PUMPS ON), chafing, damage, and proper support. Refer to TM 1-1520-240-10.				
ALL	P.31 Operate No. 1 engine gas producer (N1) and power turbine (N2) control systems. Check for freedom of motion and full travel. Refer to TM 55-1520-240-T. (Without 74)				
ALL/C	P.32 No. 1 engine oil level indicator for proper operation of low level warning system. Refer to TM 55-1520-240-T. Access 54, 55, 58				

"FOD REMINDER"

Check work area for tools and parts after completion of maintenance and inspection.

TM 55-1520-240-PM

PHASE NO. _____		Area Name and No. POWER ON CHECKS		Aircraft Serial No.	Date
Inspect Phase No's	Inspection Requirements	Status	Faults and/or Remarks	Action Taken	Initial
ALL	P.33 Operate No. 2 engine gas producer (N1) and power turbine (N2) control systems. Check for freedom of motion and full travel. Refer to TM 55-1520-240-T. (Without 74)				
ALL/C	P.34 No. 2 engine oil level indicator for proper operation of low level warning system. Refer to TM 55-1520-240-T. Access 10, 11, 74				
ALL/C	P.35 Perform functional check of No. 1 engine accessory gearbox chip detector. Refer to TM 55-1520-240-T. Access 10, 11, 55, 58				
ALL/C	P.36 Perform functional check of No. 2 engine accessory gearbox chip detector. Refer to TM 55-1520-240-T. Access 10, 11, 55, 58				
ALL/C	P.37 Perform functional check of No. 1 engine transmission temperature and chip detector assembly. Refer to TM 55-1520-240-T. Access 14, 59				
ALL/C	P.38 Perform functional check of No. 2 engine transmission temperature and chip detector assembly. Refer to TM 55-1520-240-T. Access 14, 59				

"FOD REMINDER"

Check work area for tools and parts after completion of maintenance and inspection.

TM 55-1520-240-PM

PHASE NO. _____		Area Name and No. POWER ON CHECKS		Aircraft Serial No.	Date
Inspect Phase No's	Inspection Requirements	Status	Faults and/or Remarks	Action Taken	Initial
ALL	P.39 Perform functional test of emergency exit light system. Refer to TM 55-1520-240-T.				
ALL/C	P.40 Perform flight control looseness check. Access 5, 30, 47, 72.				
ALL/C	P.41 Perform operational check on flight control system. Refer to TM 55-1520-240-T. Access 30, 34, 35, 36, 37, 38, 39, 72				
ALL	P.42 Perform functional test of forward and aft servocylinder jam indicators. Access 30, 72				
ALL/C	P.43 Perform functional test of integrated lower control actuator (ILCA) jam sensor. Refer to TM 55-1520-240-23.				
ALL	P.44 Perform operational check of forward transmission debris detection screen and chip detector. Refer to TM 55-1520-240-T.				

"FOD REMINDER"

Check work area for tools and parts after completion of maintenance and inspection.

TM 55-1520-240-PM

PHASE NO. _____		Area Name and No. POWER ON CHECKS		Aircraft Serial No.	Date
Inspect Phase No's	Inspection Requirements	Status	Faults and/or Remarks	Action Taken	Initial
ALL	P.45 Perform functional test of forward transmission XMSN OIL HOT caution light system. Refer to TM 55-1520-240-T.				
ALL	P.46 Perform functional test of forward transmission oil pressure caution light system (main and aux). Refer to TM 55-1520-240-T. Access 72				
ALL	P.47 Heater fuel system tubes and connections in cabin area and heater compartment for leaks (FUEL PUMPS ON). Refer to TM 1-1520-240-10.				
ALL	P.48 Winch cable for bends, kinks, broken or frayed strands, corrosion, and looseness of ball end. Warning paint visible on cable. Limit switches for proper operation. Level wind mechanism for proper operation.				
ALL	P.49 Perform functional test of avionics cooling fan. Refer to TM 55-1520-240-T.				
ALL	P.50 Functionally check ICS system. Refer to TM 11-1520-240-23.				

"FOD REMINDER"

Check work area for tools and parts after completion of maintenance and inspection.

TM 55-1520-240-PM

PHASE NO. _____		Area Name and No. POWER ON CHECKS		Aircraft Serial No.	Date
Inspect Phase No's	Inspection Requirements	Status	Faults and/or Remarks	Action Taken	Initial
ALL	P.51 Perform avionics inspection IAW TM 11-1520-240-23.				
ALL	P.52 Perform Aircraft Survivorability Equipment (ASE) operational check.				
	<div style="border: 1px solid black; padding: 2px; display: inline-block;">WARNING</div> <p>Ensure no personnel are directly behind or in line with the back of the exhaust of the scavenge duct when fans are started. Personnel injury could result.</p> <p style="text-align: center;">NOTE</p> <p>If EAPS is installed, perform the following checks.</p>				
ALL	P.53 Perform functional check of No. 1 engine EAPS scavenge fan. Refer to TM 55-1520-240-T.				
ALL	P.54 Perform functional check of No. 2 engine EAPS scavenge fan. Refer to TM 55-1520-240-T.				

"FOD REMINDER"

Check work area for tools and parts after completion of maintenance and inspection.

TM 55-1520-240-PM

PHASE NO. _____		Area Name and No. POWER ON CHECKS		Aircraft Serial No.	Date
Inspect Phase No's	Inspection Requirements	Status	Faults and/or Remarks	Action Taken	Initial
	NOTE				
	With EAPS bypass doors open check exposed actuator pistons for cleanliness and condition.				
ALL	P.55 Perform functional check of No. 1 engine EAPS bypass door. Refer to TM 55-1520-240-T.				
ALL	P.56 Perform functional check of No. 2 engine EAPS bypass door. Refer to TM 55-1520-240-T.				
ALL	P.57 Perform functional check of No. 1 engine EAPS differential pressure switch. Refer to TM 55-1520-240-T.				
ALL	P.58 Perform functional check of No. 2 engine EAPS differential pressure switch. Refer to TM 55-1520-240-T.				
ALL/C	P.59 Perform functional check of formation lights (normal and NVG). Refer to TM 55-1520-240-T.				

"FOD REMINDER"

Check work area for tools and parts after completion of maintenance and inspection.

TM 55-1520-240-PM

PHASE NO. _____		Area Name and No. POWER ON CHECKS	Aircraft Serial No.	Date	
Inspect Phase No's	Inspection Requirements	Status	Faults and/or Remarks	Action Taken	Initial
ALL/C	P.60 Perform functional check of dynamic absorbers. Refer to TM 55-1520-240-T.				
ALL/C	P.61 Perform functional check of flare dispenser system (if installed). Refer to TM 55-1520-240-T.				
2, 4, C	P.62 Perform hydraulic system purification check.				
ALL/C	P.63 On aircraft (With 74) engines only. Perform Aviation Vibration Analyzer (AVA) check IAW TM 1-2840-265-23 and AVA procedures.				

"FOD REMINDER"

Check work area for tools and parts after completion of maintenance and inspection.

2-90 Change 1

TM 55-1520-240-PM

PHASE NO. _____		Area Name and No. FINAL INSPECTION		Aircraft Serial No.	Date
Inspect Phase No's	Inspection Requirements	Status	Faults and/or Remarks	Action Taken	Initial
	FINAL INSPECTION				
ALL/C	F.1 Ensure that all entries on forms, records, and work sheets have been completed or updated. Initiate new forms as required. Complete the requirements of the Final Record Checklist. Refer to Figure 1-2.				
ALL	F.2 Phase completion serial number checklist.				
ALL	F.3 Perform PMD before conducting MTF.				
ALL/C	F.4 Perform a maintenance test flight IAW TM 1-1520-240-MTF.				

"FOD REMINDER"

Check work area for tools and parts after completion of maintenance and inspection.

2-91/(2-92 blank)

TM 55-1520-240-PM

By Order of the Secretary of the Army:

Official:



JOEL B. HUDSON

Administrative Assistant to the
Secretary of the Army

0309104

ERIC K. SHINSEKI
General, United States Army
Chief of Staff

DISTRIBUTION:

To be distributed in accordance with Initial Distribution Number (IDN) 310196, requirements for TM 55-1520-240-PM.

